

Panasonic

2.4GHz Cordless Answering System

Model No. **KX-TG2583B**
KX-TG2583S
KX-TG2583W

Pulse-or-tone dialing capability

Operating Instructions



KX-TG2583B

Caller ID Compatible

PLEASE READ BEFORE USE AND SAVE.

Charge the battery for about 6 hours before initial use.

Panasonic World Wide Web address: <http://www.Panasonic.com>
for customers in the USA or Puerto Rico

Preparation

Cordless Telephone

Answering System

Useful Information

For Best Performance

Battery Charge

A rechargeable Ni-Cd battery powers the handset Charge the battery for about 6 hours before initial use (p 11)



Base Unit Location/Noise

Calls are transmitted between the base unit and the handset using wireless radio waves **For maximum distance and noise-free operation**, the recommended base unit location is

Away from electrical appliances such as a TV, personal computer or another cordless phone

In a HIGH and CENTRAL location with no obstructions such as walls

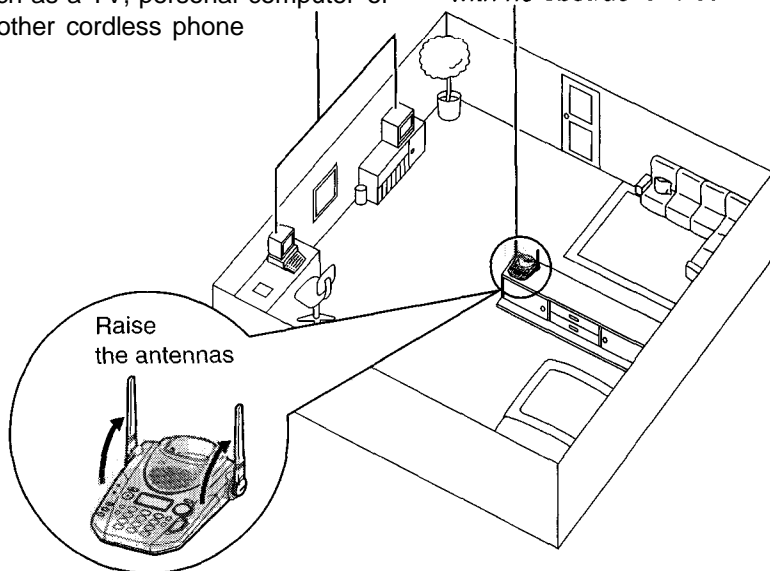

Note:

While using the handset

- If you are near a microwave oven which is being used, noise may be heard from the receiver Move away from the microwave oven and closer to the base unit
- If more than one cordless phone is being used and your handset is near another cordless phone's base unit, noise may be heard Move away from the other cordless phone's base unit and closer to your base unit

Contents

Preparation

Location of Controls	6
Displays	9
Settings	10
Connections	10
Battery Charge	11
Selecting the Dialing Mode	13
Selecting the Line Mode	14
Programmable Functions	15
Setting the Auto Talk Feature	16
Selecting the Ringer Volume	17
Preparing the Answering System	19
Greeting Message	19
Programming Summary for the Answering System	21
Day and Time Adjustment	22
Selecting the Caller's Recording Time	24
Selecting the Number of Rings	25

Cordless Telephone

Making Calls	26
With the Handset	26
With the Base Unit (Digital Duplex Speakerphone)	28
Simultaneous Keypad Dialing	30
Answering Calls	31
With the Handset	31
With the Base Unit (Digital Duplex Speakerphone)	31
Caller ID Service	32
Using the Caller List	34
Viewing the Caller List	34
Calling Back from the Caller List	35
Editing the Caller's Phone Number	36
Storing Caller List Information in the Directory	38
Erasing Caller List Information	39
One-Touch Dialer	41
Storing a Phone Number in the DIRECT Button	41
Dialing the Stored Number in the DIRECT Button	42
Using the Directory	43
Storing Names and Numbers in the Directory	43
Selecting Characters to Enter Names	45
Finding Items in the Directory	47
Dialing from the Directory	49

Editing an Item in the Directory	50
Erasing an Item from the Directory	51
Intercom	52
Transferring a Call Using the Intercom	53
Special Features	54
Automatic Security Code Setting	54
For Call Waiting Service Users	54
How to Use the PAUSE Button	
(For Analog PBX Line/Long Distance Service Users)	54
Temporary Tone Dialing	
(For Rotary or Pulse Service Users)	55
FLASH Button	55

Answering System

Automatic Answering Operation	56
Setting the Unit to Answer Calls	56
Listening to Messages	57
From the Handset	58
Erasing Messages	59
Remote Operation from a Touch Tone Phone	60
Setting the Remote Code	61
Voice Menu	62
Direct Remote Operation	64
Remote Operation with the Handset	66

Useful Information

Wall Mounting	68
Using the Belt Clip	70
Using an Optional Headset	70
Battery Replacement	71
If the Following Appear...	72
Before Requesting Help	74
Adding Another Phone	79
Important Safety Instructions	80
FCC and Other Information	82

Location of Controls

Base unit

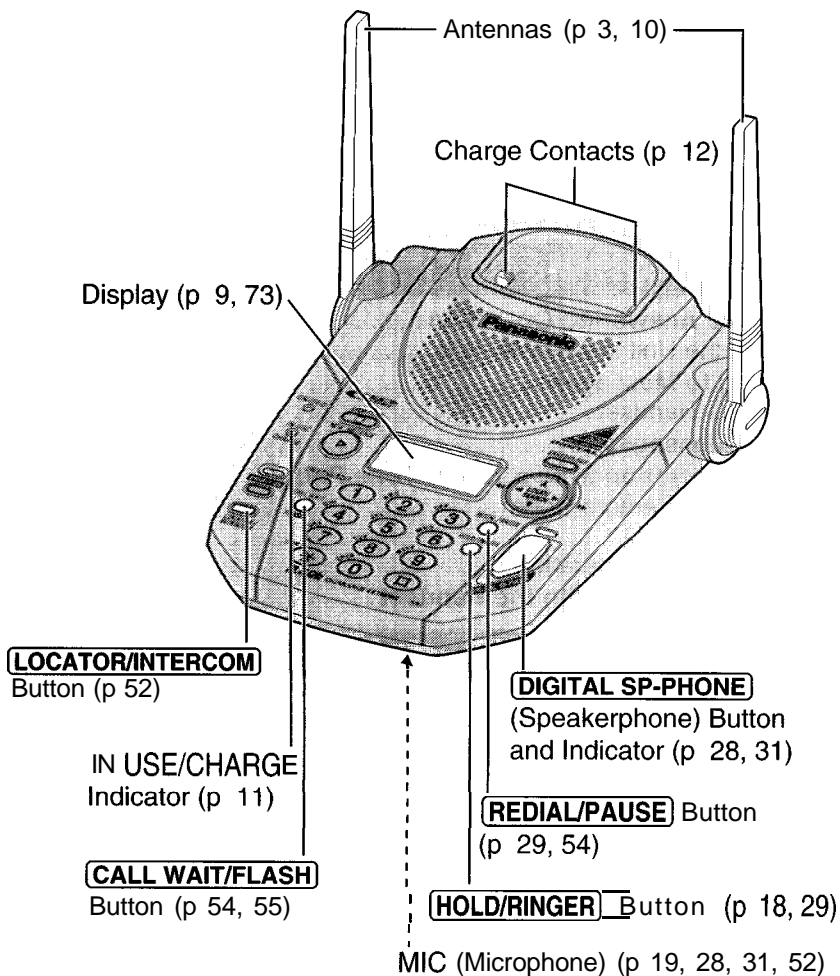

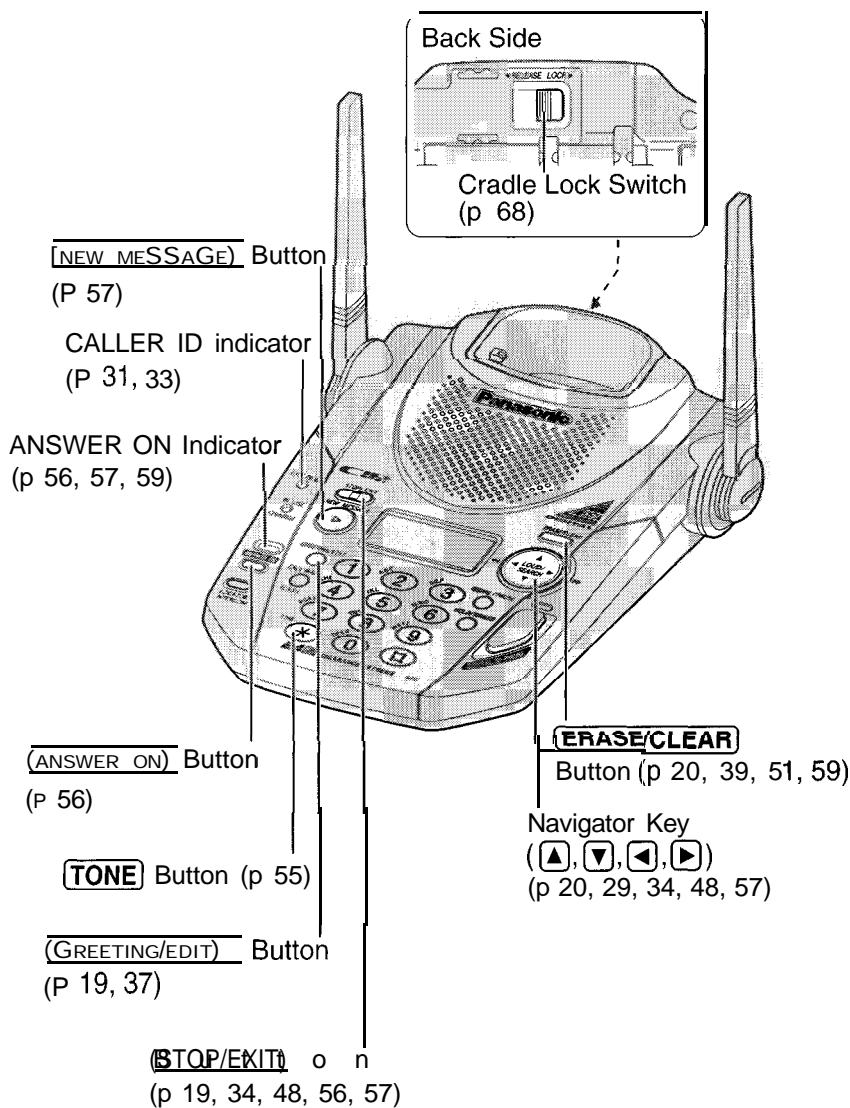

Location of Controls

Handset

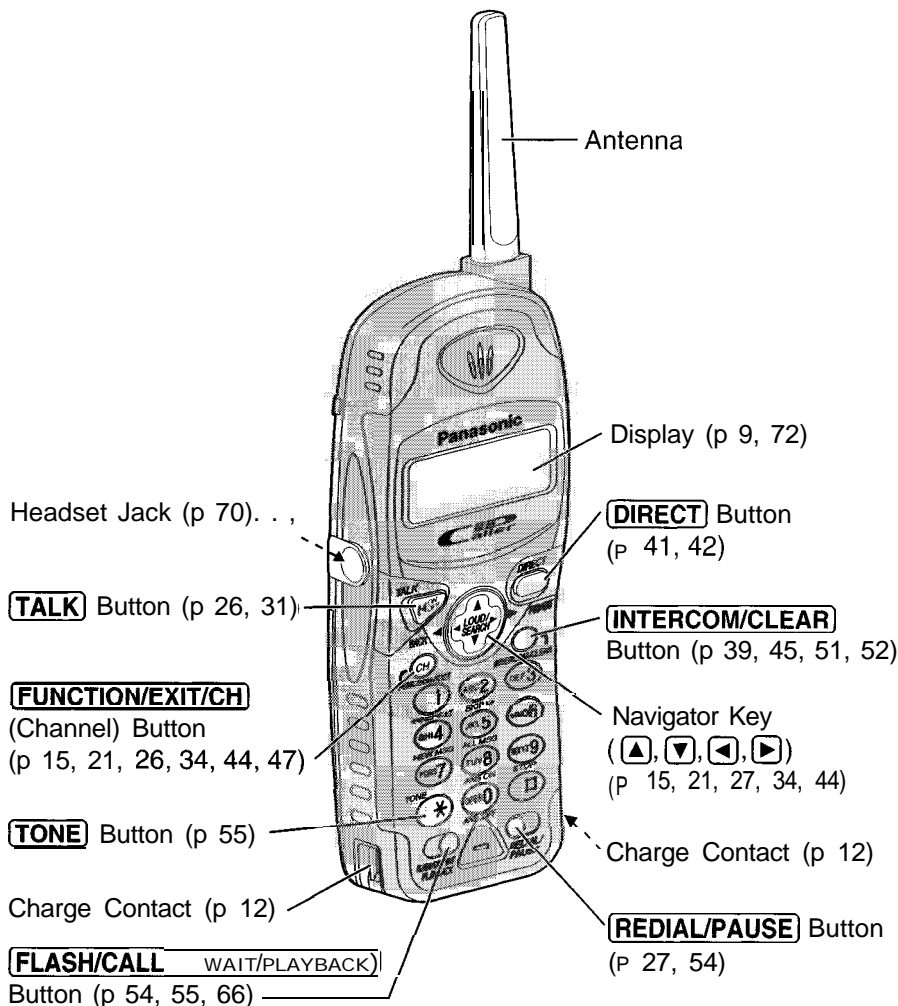

Displays

Handset

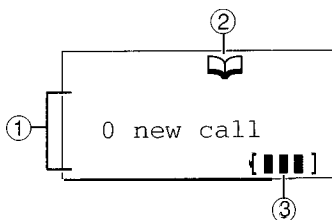

① The display shows the dialed number, call status, programming options and directory items etc. If you subscribe to a Caller ID service, caller information will be displayed (p 32). The number of new calls will also be displayed.

② The directory icon displays when storing or viewing the directory items (P 44, 47)

@ The battery icon indicates the battery strength (p 11)

Standby mode:

While the handset is off the base unit, the display becomes blank after you finish using the handset (making/answering a call, viewing the Caller List or directory list etc). The handset can receive calls. The battery life is conserved in this state. While the handset is on the base unit, the battery icon and the number of new Caller ID calls are displayed in the standby mode (p 33)

Base unit

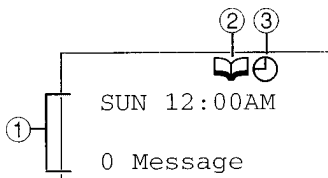

@ The day and time and the number of incoming messages are displayed while the unit is not in use (**Standby mode**). The display shows the dialed number, call status, programming options and directory items etc. If you subscribe to a Caller ID service, caller information will be displayed (p 32). The number of new calls will also be displayed.

@ The directory icon displays when viewing the directory items (p 48)

@ The clock icon flashes with the day and time if the clock needs adjusting (p 22)

Settings

Connections

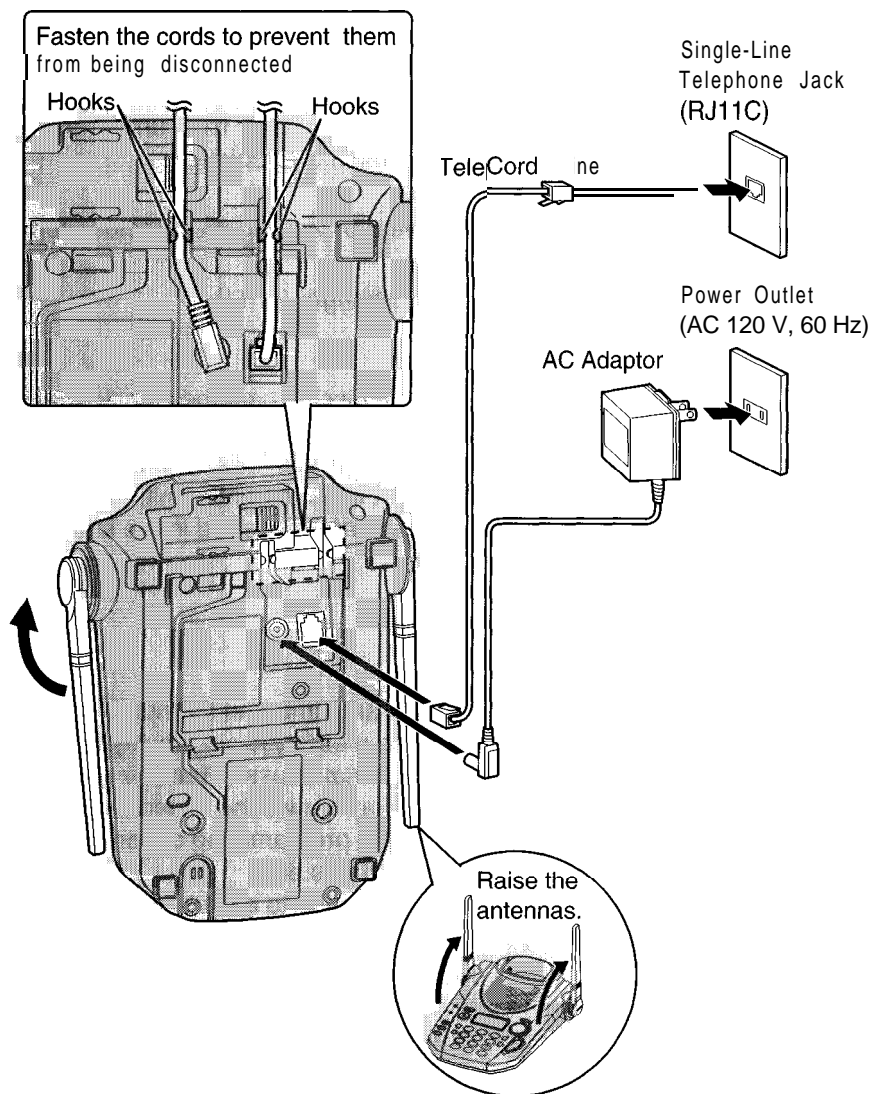

*USE ONLY WITH Panasonic AC ADAPTOR PQLV10 (Order No PQLV1 OZ)

*The AC adaptor must remain connected at all times (It is normal for the adaptor to feel warm during use)

•To connect a standard telephone on the same line, see page 79

*If your unit is connected to a PBX which does not support Caller ID services, you cannot access those services



Battery Charge

Place the handset on the base unit and charge for about 6 **hours** before initial use

*The IN USE/CHARGE indicator lights and a beep sounds

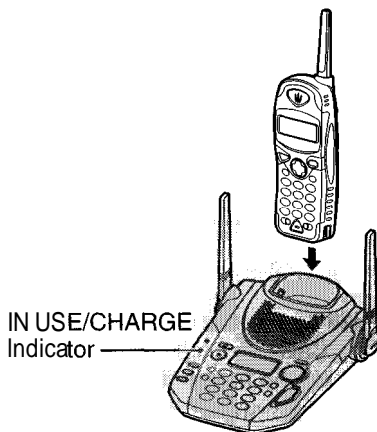

Preparation

Battery strength

You can check the battery strength on the handset display while the handset is on the base unit, while it is in use (making/answering a call etc), or after viewing the Caller List or directory items, programming etc The battery strength will remain for 5 seconds after using the handset, then the display will return to the standby mode (p 9)

The battery strength is as shown in the chart below

Display prompt	Battery strength
{ ■■■ }	Fully charged
{ ■■ }	Medium
{ ■ }	Low
{ ■ } (flashing)	Needs to be recharged

Recharge

Recharge the battery when

- “Recharge battery” is displayed on the handset,
- “{ ■ }” flashes on the display, or
- the handset beeps intermittently while it is in use

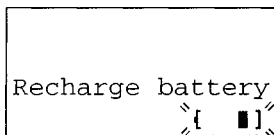

- If you DO NOT recharge the handset battery for more than 15 minutes, the display will keep indicating “Recharge battery” and/or “{ ■ }” will continue to flash

battery information

After your Panasonic battery is fully charged (p 11)

Operation		Approx. battery life
While in use (TALK)	near the base unit*	Up to 4 5 hours
	away from the base unit	Up to 3 5 hours
While not in use (Standby)		Up to 11 days

*Within about 10 feet (3 m)

- Battery life may be shortened depending on usage conditions, such as viewing the Caller ID Caller List or directory list, and ambient temperature
- **Clean the handset and the base unit charge contacts with a soft, dry cloth once a month. Clean more often if the unit is subject to grease, dust or high humidity.** Otherwise the battery may not charge properly
- **If** the battery is fully charged, you do not have to place the handset on the base Unit Until **"Recharge battery"** is displayed and/or **"[I]"** flashes This will maximize the battery life
- The battery cannot be overcharged



Selecting the Dialing Mode

You can program the dialing mode using the handset near the base unit

If you have touch tone service, set to "Tone" If rotary or pulse service is used, set to "Pulse" Your phone comes from the factory set to "Tone"

Make sure the unit is in the standby mode initially.

- 1 Press **FUNCTION/EXIT/CH**

▶Save directory
Ringer volume
▼▲ ▶=Yes

- 2 Press ▼ or ▲ repeatedly until the arrow points to "Program"

▶Program
▼▲ ▶=Yes

- 3 Press **FWD/EDIT** (Yes key)

▶Save DIRECT#
Set flash time
▼▲ ▶=Yes

- 4 Press ▼ or ▲ repeatedly until the arrow points to "Set dial mode"

Set line mode
▶Set dial mode
▼▲ ▶=Yes

- 5 Press **FWD/EDIT** (Yes key)

Dial mode
:Tone
▼▲ ▶=Save

- 6 Press ▼ or ▲ to select "Pulse" or "Tone"

Dial mode
:Pulse
▼▲ ▶=Save

- 7 Press **FWD/EDIT** (Save key)
 - A beep, sounds
 - To return to the standby mode, press **FUNCTION/EXIT/CH**

Dial mode
:Pulse

- YOU can exit the programming mode any time by pressing **FUNCTION/EXIT/CH**
- If the handset has lost communication with the base unit, 3 beeps sound and "No link to base" Place on cradle and try again "isdisplayed"

Selecting the Line Mode

If the line is connected to a low voltage system such as a PBX, set to "B"
 Otherwise the Call Waiting Caller ID Feature may not be used (p 54)
 Your phone comes from the factory set to "A"

Use the handset near the base unit.

Make sure the unit is in the standby mode initially.

1 Press **FUNCTION/EXIT/CH**

```
▶Save directory
  Ringer volume
▼▲ ▶=Yes
```

2 Press **▼** or **▲** repeatedly until the arrow points to "Program"

```
▶Program
▶=Yes
```

3 Press **FWD/EDIT** **▶** (Yes key)

```
▶Save DIRECT#
  Set flash time
▼▲ ▶=Yes
```

4 Press **▼** or **▲** repeatedly until the arrow points to "Set line mode"

```
▶Set line mode
  Set dial mode
▼▲ ▶=Yes
```

5 Press **FWD/EDIT** **▶** (Yes key)

```
Line mode
: A
▼▲ ▶=Save
```

6 Press **▼** or **▲** to select "B" or "A"

```
Line mode
: B
▼▲ ▶=Save
```

7 Press **FWD/EDIT** **▶** (save key)

- A beep sounds
- To return to the standby mode, press

FUNCTION/EXIT/CH

```
Line mode
: B
```

- You can exit the programming mode any time by pressing **FUNCTION/EXIT/CH**
- If the handset has lost communication with the base unit, 3 beeps sound and "No link to base Place on cradle and try again" is displayed

Programmable Functions



You can program the following function items **using the handset near the base unit**. The display shows the programming instructions. See the corresponding pages for function details.

Make sure the unit is in the standby mode initially.

Press **FUNCTION/EXIT/CH**



<Function menu>*

▶ Save directory
Ringer volume
Program

To store an item in the directory (p 44)

To select the ringer volume (p 17)

Press **FWD/EDIT**

<Function menu>*

▶ Save DIRECT#

Set flash time
Set line mode
Set dial mode
Talk switching
TAD program

To store a phone number in the DIRECT button (p 41)

To select the flash time (p 55)

To select the line mode (p 14)

To select the dial mode (p 13)

To set the auto talk feature (p 16)

To program answering system functions (p 21)

During programming:

*To select a desired function item, press or repeatedly until the arrow points to the item. Then press **FWD/EDIT** to go to the next step.

- You can exit the programming mode any time by pressing **FUNCTION/EXIT/CH**.
- If you do not press any buttons for 60 seconds, the unit will return to the standby mode.
- If the handset has lost communication with the base unit, 3 beeps sound and "NO link to base" is displayed. Place on cradle and try again.

➡ Programmable Functions

Setting the Auto Talk Feature

The Auto Talk feature allows you to answer a call by lifting the handset off the base unit without pressing **TALK**. If you want to use this feature, turn the feature ON by programming. Your phone comes from the factory set to OFF.

Make sure the unit is in the standby mode initially.

1 Press **FUNCTION/EXIT/CH**

2 Press **▼** or **▲** repeatedly until the arrow points to "Program"

```
▶Program
▼▲                               ▶=Yes
```

3 Press **FWD/EDIT** **▶** (Yes key)

4 Press **▼** or **▲** repeatedly until the arrow points to "Talk switching"

```
▶Talk switching
TAD program
▼▲                               ▶=Yes
```

5 Press **FWD/EDIT** **▶** (Yes key)

```
Auto talk
:Off
▼▲                               ▶=Save
```

6 Press **▼** or **▲** to select "On" or "off"

```
Auto talk
:On
▼▲                               ▶=Save
```

7 Press **FWD/EDIT** **▶** (Save key)

- A beep sounds
- To return to the standby mode, press **FUNCTION/EXIT/CH**

```
Auto talk
:On
```

- You can exit the programming mode any time by pressing **FUNCTION/EXIT/CH**
- In order to view Caller ID information before answering a call, leave the Auto Talk feature OFF



Selecting the Ringer Volume

With the handset

You can set the handset ringer volume to HIGH, LOW or OFF. If set to OFF, the handset will not ring. Your phone comes from the factory set to HIGH.

Make sure the unit is in the standby mode initially.

- 1 Press **FUNCTION/EXIT/CH**
- 2 Press **▼** or **▲** repeatedly until the arrow points to "Ringer volume"
- 3 Press **FWD/EDIT** (Yes key)
- 4 Press **▼** or **▲** to select the desired volume
 - The selected volume is displayed and rings
 - To turn the ringer OFF**, press and hold **▼** until 2 beeps sound

To turn the ringer ON, press **▲** or **▼** in step 4

•The ringer will sound at the LOW level

•You can also select the ringer volume while a call is being received. Press **▼** or **▲** while the unit is ringing.

*When set to OFF, "Ringer off" will flash for about 45 seconds before the handset returns to the standby mode.

•When you replace the battery, the selected ringer volume setting will return to the factory set (HIGH). Reprogram if necessary.

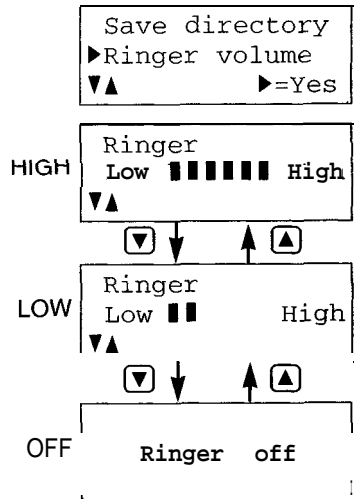

➡ Programmable Functions

With the base unit

You can set the base unit ringer volume to HIGH, LOW or OFF. If set to OFF, the base unit will not ring. Your phone comes from the factory set to HIGH.

Make sure the unit is in the standby mode initially (You can also select the ringer volume while a call is being received.)

To select **HIGH** or **LOW**, press

HOLD/RINGER

*Each time you press the button, the selected ringer volume will be displayed and ring.

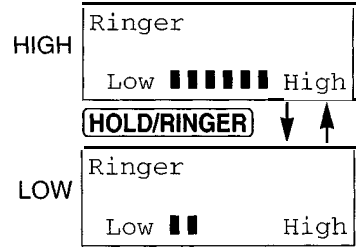

To turn the ringer **OFF**, press and hold

HOLD/RINGER until 2 beeps sound.

*"Ringer off" will be displayed.

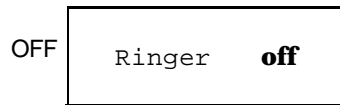

To turn the ringer **ON**, press

HOLD/RINGER

*The ringer will sound at the HIGH level.



Preparing the Answering System

Greeting Message

You can record a personal greeting message of **up to 2 minutes**. If a greeting message is not recorded, one of two pre-recorded greetings will be played when a call is received (p 20)

All messages (greeting, incoming, etc) are stored in digital memory (p 20). The **total recording time is about 15 minutes**.

We recommend you record a **brief greeting message** (see sample on next page) in order to leave more time for recording new messages.

To record a greeting message

- 1 Press and hold **GREETING/EDIT** until a long beep is heard

Greeting record
00-00

- 2 Talk clearly, about 8 inches (20 cm) away from the **MIC** (microphone)

- The base unit display shows the elapsed recording time
- If you record for over 2 minutes, the unit will automatically stop recording

Greeting record
00-12



- 3 When finished, press **STOP/EXIT**

- To check the recorded greeting, press **GREETING/EDIT** briefly

Greeting check
00-12

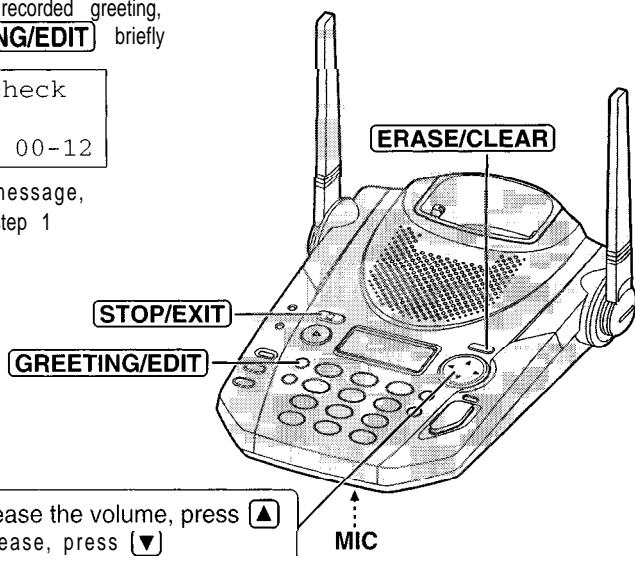
- To change the message, start again from step 1



To increase the volume, press 
To decrease, press 

➡ Preparing the Answering System

To adjust the speaker volume:

9 levels (0-8) are available while using the answering system To increase, press ▲

To decrease, press ▼

Ex Level 8

Loud

Low ■■■■■■■■ High

Greeting message sample

“Hello, this is (your name and/or number) Sorry I cannot take your call Please leave a message after the beep Thank you ”

To erase the recorded greeting message

Press (GREETING/EDIT) briefly ➡ press (ERASE/CLEAR) while the message is being played

*The unit will answer a call with a pre-recorded greeting

Pre-recorded greeting message

If you do not record a greeting message (p 19), one of two messages will be played when a call is received, depending on the caller's recording time (p 24)

To check the pre-recorded greeting, press (GREETING/EDIT) briefly

•A pre-recorded greeting will be played as follows

- When the recording time is set to “1 minute” or “3 minutes”

“Hello, we are not available now Please leave your name and phone number after the beep We will return your call ”

- When the recording time is set to “Greeting only”

“Hello, we are not available now Please call again Thank you for your call ”

Flash Memory Message Backup

Messages are stored on a “flash memory” IC chip and will not be affected by power failures All messages are saved until you erase them



Programming Summary for the Answering System

You can program the following functions using the handset near the base unit. Make sure the unit is in the standby mode initially.

Press **FUNCTION/EXIT/CH**



Press **▼** or **▲** to select "Program", and press **FWD/EDIT** **▶** (Yes key)



Press **▼** or **▲** to select "TAD program", and press **FWD/EDIT** **▶** (Yes key)

*"Answering system setting See base unit " is displayed on the handset



The base unit display shows programming options Enter a required command on the display using the handset dialing buttons See the page numbers for details

0=Day and time
1=Remote code
2=Number of ring

Adjusts the day and time (p 22)
Sets the remote code (p 61)
Selects the number of rings (p 25)

5=Recording time

Selects the caller's recording time (p 24)

*The display will change every 3 seconds



Press **FWD/EDIT** **▶** (save key)

- You can exit the programming mode any time by pressing **FUNCTION/EXIT/CH**
- If you do not press any buttons for 60 seconds, the unit will return to the standby mode
- If 6 beeps sound on the base unit during programming, a wrong key was pressed Enter the correct number
- If the handset has lost communication with the base unit, 3 beeps sound and "No link to base Place on cradle and try again " is displayed on the handset

➡ Preparing the Answering System

Day and Time Adjustment

Voice Time/Day Stamp: During playback, a synthesized voice will announce the day and time that each message was recorded

1 Press **FUNCTION/EXIT/CH**

```
▶Save directory
Ringer volume
▼▲ ▶=Yes
```

2 Press **▼** or **▲** repeatedly until the arrow points to "Program"

```
▶Program
▶.=Yes
```

3 Press **FWD/EDIT** **▶** (Yes key)

```
▶Save DIRECT#
Set flash time
▼▲ ▶=Yes
```

4 Press **▼** or **▲** repeatedly until the arrow points to "TAD program"

```
Talk switching
▶TAD program
▼▲ ▶=Yes
```

5 Press **FWD/EDIT** **▶** (Yes key)
•The base unit display shows programming options

```
Answering
system setting
See base unit
```

6 Press **0**
*“Set time” is announced
If previously adjusted, the day/time will be heard

Base unit display

```
SUN 12:00 AM
* =AM/PM # =Day
```

7 Enter the time (hour and minute) using a 4-digit number
(Ex To set 9 30, enter "0930")

8 Press ***** to select "AM" or "PM"
Press **#** repeatedly to set the day

9 Press **FWD/EDIT** (Save key)

*The unit announces the day/time. The clock starts working.

- If 6 beeps sound, the setting is not correct. Start again from step 5.
 - To return to the standby mode, press **FUNCTION/EXIT/CH**.
- In step 7, you cannot enter numbers greater than 12. **Do not use military time.**
(To set 13:00 hours, enter "01 00", and select "PM" by pressing )

If a power failure occurs, the adjusted day/time will be erased. Readjust the day/time.

For Caller ID service users (p. 32)

- The Caller ID information will re-set the clock after the first ring if the adjusted time is incorrect. However, the day will not be re-set. Set the day following the procedures on pages 22 and 23.
- If the time has not previously been set, the Caller ID information will not adjust the clock.
- The Caller ID information will automatically adjust the clock for daylight saving time.

Selecting the Caller's Recording Time

You can select "1 minute", "3 minutes" or "Greeting only" for the caller's recording time. Your phone comes from the factory set to "3 minutes"

1 Press **FUNCTION/EXIT/CH**

```
▶Save directory
  Ringer volume
▼▲ ▶=Yes
```

2 Press **▼** or **▲** repeatedly until the arrow points to "Program"

```
▶Program
▼▲ ▶=Yes
```

3 Press **FWD/EDIT** **▶** (Yes key)

```
▶Save DIRECT#
  Set flash time
▼▲ ▶=Yes
```

4 Press **▼** or **▲** repeatedly until the arrow points to "TAD program"

```
Talk switching
▶TAD program
▼▲ ▶=Yes
```

5 Press **FWD/EDIT** **▶** (Yes key)

*The base unit display shows programming options

```
Answering
system setting
See base unit
```

6 Press **5**

*The current setting is displayed on the base unit

```
Base unit display
Recording time
:3min
```

7 Press **1**, **2** or **3** to select the recording time

- 1 1 minute
- 2 3 minutes
- 3 Greeting only

```
Base unit display
Recording time
:Greeting only
```

8 Press **FWD/EDIT** **▶** (Save key)

•A beep sounds

•To return to the standby mode, press **FUNCTION/EXIT/CH**

If you select "Greeting only", the unit will answer a call with the greeting message, and then hang up. The unit will not record any incoming messages. The base unit display will show "Greeting only" in the standby mode but the number of incoming messages will not be displayed.

Selecting the Number of Rings

You can select the number of times the unit rings before the answering system answers a call, from "2" to "7" or "Toll saver"*

Your phone comes from the factory set to "Toll saver"*

- 1 Press **FUNCTION/EXIT/CH**

▶ Save directory
 Ringer volume
 ▼▲ ▶=Yes
- 2 Press **▼** or **▲** repeatedly until the arrow points to "Program"

▶ Program
 ▼▲ ▶=Yes
- 3 Press **FWD/EDIT** **▶** (Yes key)

▶ Save DIRECT#
 Set flash time
 ▼▲ ▶=Yes
- 4 Press **▼** or **▲** repeatedly until the arrow points to "TAD program"

Talk switching
 ▶ TAD program
 ▼▲ ▶=Yes
- 5 Press **FWD/EDIT** **▶** (Yes key)

Answering
 system setting
 See base unit

 - The base unit display shows programming options
- 6 Press **2**

Base unit display
 Number of rings
 :Toll saver

 - The current setting is displayed on the base unit
- 7 Press **0**, or **2** to **7** to set the number of rings
 - 0: Selects "Toll saver"*
 - 2-7: The unit will answer after the selected number of rings
- 8 Press **FWD/EDIT** **▶** (Save key)
 - A beep sounds
 - To return to the standby mode, press **FUNCTION/EXIT/CH**

*Toll saver

When you call the unit from a touch tone telephone

If the unit answers on the 2nd ring, there is at least one new message

If the unit answers on the 4th ring, there are no new messages

Hang up when you hear the 3rd ring. This will save you the toll charge for the call

Making Calls

With the Handset

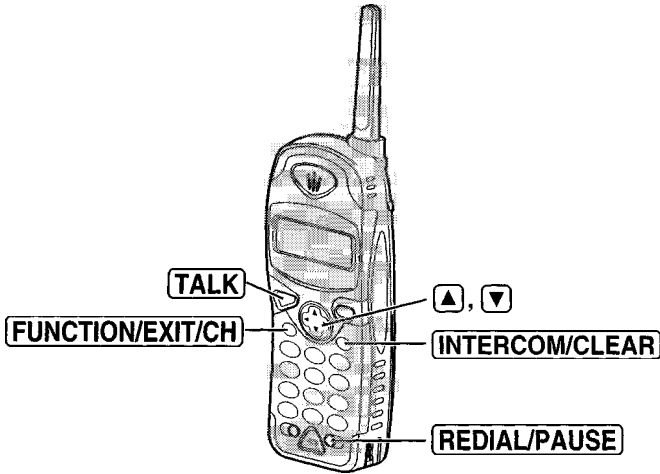

1 Press **TALK**

Talk

2 Dial a phone number

•The dialed number is displayed

*After a few seconds, the display will show the length of the call and the battery strength

Talk
1112222

Talk
00-00-00 [■■■■]

3 To hang up, press **TALK** or place the handset on the base unit

Off
00-01-08 [■■■■]

•If the handset has lost communication with the base unit, 3 beeps sound and "No link to base Place on cradle and try again" is displayed

If noise interferes with the conversation

Press **FUNCTION/EXIT/CH** to select a clearer channel or move closer to the base unit

To redial the last number dialed on the handset

Press **TALK** and press **REDIAL/PAUSE**



To dial after confirming the entered number

- 1 Dial a phone number
 - If you misdial, press **INTERCOM/CLEAR** and dial again
- 2 Press **TALK**
 - *After a few seconds, the display will show the length of the call and the battery strength
- 3 To hang up, press **TALK** or place the handset on the base unit

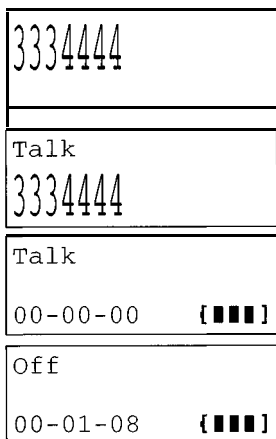

To redial after confirming the last number dialed

Press **REDIAL/PAUSE** and press **TALK**

To adjust the receiver volume while talking

- To increase, press **▲**
 To decrease press **▼**
- *Each time you press **▼** or **▲**, the volume level will change
- The display will return to the length of the call

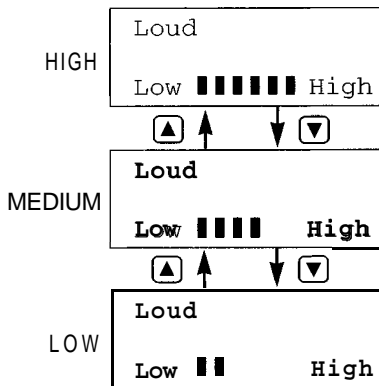

Lighted handset keypad

The handset dialing buttons will light when you press a button or lift the handset off the base unit, and flash when a call is received. The lights will go out a few seconds after pressing a button, lifting the handset or answering a call.

Backlit LCD display

The lighted handset display will stay on for a few seconds after pressing a handset button or lifting the handset off the base unit.

Cordless Telephone

➔ Making Calls

With the Base Unit (Digital Duplex Speakerphone)

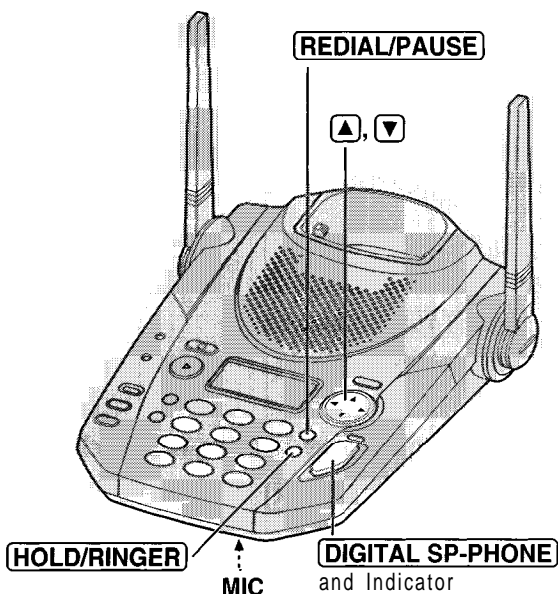

- 1 Press **DIGITAL sp-PHONE**
•The DIGITAL SP-PHONE indicator lights

Talk

- 2 Dial a phone number

Talk
1112222

- 3 When the other party answers, talk into the MIC (microphone)

Talk
00-00-00

- 4 To hang up, press **DIGITAL SP-PHONE**
•The indicator light goes out

Off
00-00-00



- To switch to the handset while using the base unit speakerphone
 - If the handset is off the base unit, press **TALK**
 - If on the base unit, just lift up

*During a call using the handset, the call can be switched to the speakerphone by pressing **DIGITAL SP-PHONE**





Hands-free Digital Duplex Speakerphone

For best performance, please note the following

- Talk alternately with the caller in a quiet room
- If the other party has difficulty hearing you, press  to decrease the speaker volume
- If the other party's voice from the speaker cuts in/out during a conversation, press  to decrease the speaker volume

To adjust the speaker volume (8 levels) while talking

To increase, press 

To decrease, press 

Ex Level 8



To redial the last number dialed on the base unit

Press DIGITAL SP-PHONE and press REDIAUPAUSE

To put a call on hold

Press HOLD/RINGER

- The DIGITAL SP-PHONE indicator flashes



To release the hold

From the base unit, press DIGITAL SP-PHONE

From the handset, press TALK or lift the handset off the base unit

- If another phone is connected on the same line (p 79), you can also release the hold by lifting its handset

➔ Making Calls

Simultaneous Keypad Dialing

You can use the base unit like a standard telephone. After pressing **TALK** to make a call with the handset near the base unit, you can also dial using the base unit keypad.

- 1 Handset
Press **TALK**
- 2 Base unit
Dial a telephone number while hearing a dial tone on the handset
*When the other party answers, talk using the handset
- 3 Handset
To hang up, press **TALK** or place the handset on the base unit

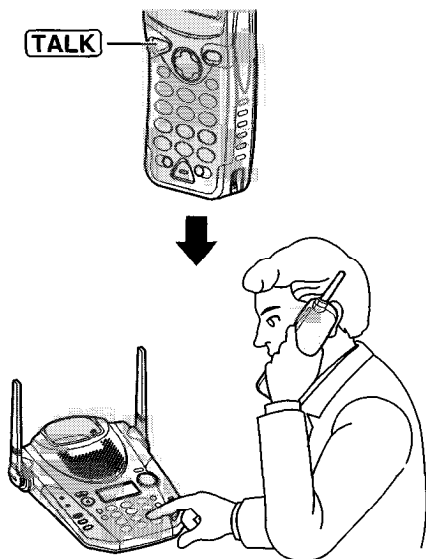

Simultaneous Keypad Dialing is only possible after pressing **TALK**.

Useful information

You can enter numbers using the base unit keypad during a call with the handset. For example, to access an answering service, electronic banking service, etc.

- 1 Handset
Press **TALK**
- 2 Handset
Dial a telephone number
•You can also dial with the base unit keypad
- 3 Base unit
Enter the required numbers while listening to the pre-recorded instructions
- 4 Handset
To hang up, press **TALK** or place the handset on the base unit

Answering Calls

When a call is received, the unit rings, "Incoming call" is displayed and the CALLER ID indicator flashes quickly

If you subscribe to a Caller ID service, the calling party information will be displayed after the first ring (p 32) In order to view the Caller ID information, please wait until the second ring to answer a call

With the Handset

If the handset is off the base unit, press **TALK**

- You can also answer a call by pressing any dialing button **0** to **9**, ***** or **#** (-Any Key Talk)

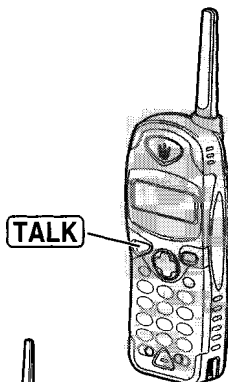

Auto Talk

If you set the Auto Talk feature to ON (p 16), you can answer a call by lifting the handset off the base unit without pressing **TALK**

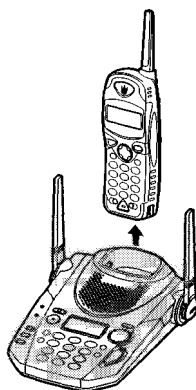

With the Base Unit (Digital Duplex Speakerphone)

- 1 Press **DIGITAL SP-PHONE**
- 2 Talk into the MIC
- 3 To hang up, press **DIGITAL SP-PHONE**

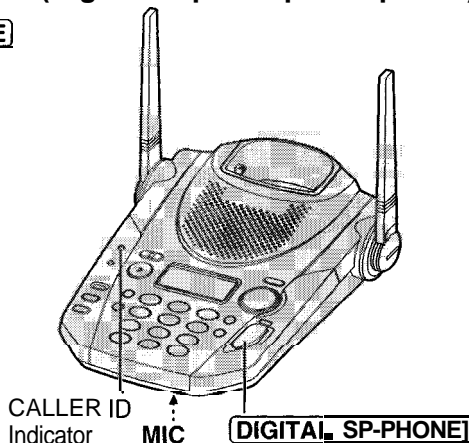

Caller ID Service

This unit is compatible with a Caller ID service offered by your telephone company. If you subscribe to a Caller ID service, the calling party's information will be shown on the handset and base unit displays after the first ring.

The unit can record information of up to 50 different callers in the Caller List. The Caller List information is sorted by the most recent to the oldest call. When the 51st call is received, the first call is deleted.

Using the list, you can automatically call back a caller. You can store the callers' names and numbers from the Caller List into the directory.

If you subscribe to both Caller ID and Call Waiting services, when a second call is received while talking, the new caller's name and phone number will be displayed (p 54).

How caller information is displayed when a call is received

The handset and base unit displays show the caller's name and number after the first ring.

- After you answer the call, the display will show the length of the call.

TINA ROBINSON
1-000-222-3333

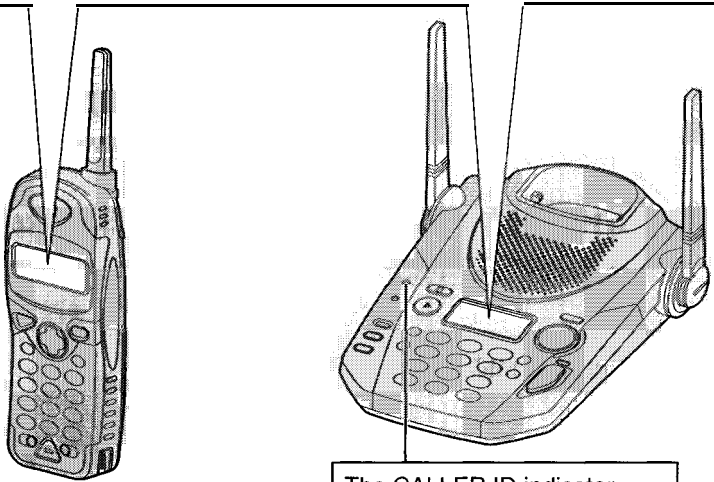

The CALLER ID indicator light will flash quickly when a call is being received.

- Caller information cannot be displayed in the following cases
 - If the caller dialed from an area which does not provide a Caller ID service, the display will show "Out of area"
 - If the caller has requested not to display his/her information, the display will show "Private caller"
- If your unit is connected to a PBX which does not support Caller ID services, you cannot access those services
- The name display service may not be available in some areas For further information, please contact your telephone company

To check the number of new calls

When new calls have been received, the CALLER ID indicator flashes slowly on the base unit The handset and base unit displays show the number of new calls

Ex. You have received 10 new calls.

While the handset is on the base unit:

Handset display

```
10 new calls
[||||]
```

Base unit display

```
SUN 12:00AM
10 new calls
_0_message_
```

CALLER ID
Indicator

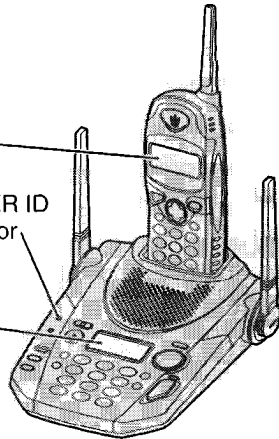

While the handset is off the base unit:

Press or to turn the display on

```
(, : - . ; | , : ; : : ,
```

,



- If "No items stored" is displayed, the Caller List is empty



Using the Caller List

Viewing the Caller List

You can view the caller list with the handset or the base unit. Caller List information includes the caller's name and phone number, the time and date the call was received, and the number of times that caller called (p 35)



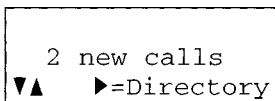

Make sure the unit is in the standby mode initially.

With the handset

- 1 Press  or  to enter the Caller List
 - The display will show, for example, the following



```
2 new calls
▼▲ ▶=Directory
```

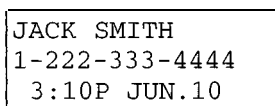

- You can go to the directory list by pressing **FWD/EDIT**  (p 47)
- 2 To search from the most recent call, press . To search from the oldest call, press .
 - To scroll between callers, press  or .



```
JACK SMITH
1-222-333-4444
3:10P JUN.10
```



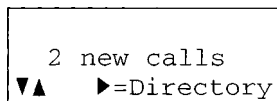

- 3 To exit the list, press **(FUNCTION/EXIT/CH)**
 - The handset will return to the standby mode

With the base unit

- 1 Press  or  to enter the Caller List
 - The display will show, for example, the following



```
2 new calls
▼▲ ▶=Directory
```

- You can go to the directory list by pressing  (p 48)
- 2 To search from the most recent call, press . To search from the oldest call, press .
 - To scroll between callers, press  or .

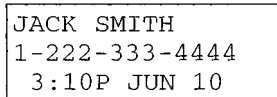

```
JACK SMITH
1-222-333-4444
3:10P JUN 10
```

- 3 To exit the list, press **(STOP/EXIT)**
 - The base unit will return to the standby mode

*If "No items stored" is displayed, the Caller List is empty

- If there is no name information for a caller, the display will only show the phone number
- While you are viewing the Caller List with the handset, another person cannot access the list using the base unit, and vice versa



What “√” means

When the display shows “√”, you have already viewed this calling information, answered the call, called back the caller or played back the message (p 57) If the same caller calls again, the call entry with “√” will be replaced with the new call entry

```
JACK SMITH
1-222-333-4444
3:10P JUN.10 √
```

If a caller calls more than once

The number of times the same caller called is displayed (X2 to X9) The date and time of the most recent call will be recorded After checking, X2 to X9 will be replaced with “√”

```
JACK SMITH
1-222-333-4444
3:10P JUN 10 X3
```

Calling Back from the Caller List

With the handset

- 1 Press or to enter the Caller List

```
3 new calls
▼▲ ▶=Directory
```

- 2 Press or repeatedly to find the desired caller

```
CINDY TURNER
1-234-456-7890
11:20A JAN 12 X3
```

- 3 Press **(TALK)**
•The displayed phone number is dialed automatically

```
Talk
12344567890
```

With the base unit

- 1 Press or to enter the Caller List

```
3 new calls
▼▲ ▶=Directory
```

- 2 Press or repeatedly to find the desired caller

```
CINDY TURNER
1-234-456-7890
11:20A JAN.12 X3
```

- 3 Press **(DIGITAL SP-PHONE)**
*The displayed phone number is dialed automatically

```
Talk
112344567890
```

- In some cases, you may have to edit the number before dialing (p 36, 37)
(Ex You may have to delete “1” and the area code)
- If a phone number is not displayed in the caller information, you cannot call back that caller

➔ Using the Caller List

Editing the Caller's Phone Number

You can edit a phone number into one of 4 patterns using the handset or the base unit

Make sure the unit is in the standby mode initially.

With the handset

1 Press **▼** or **▲** to enter the Caller List

```
5 new calls
▼▲ ▶=Directory
```

2 Press **▼** or **▲** repeatedly to find the desired caller, and press **FWD/EDIT** **▶**

```
FRED PARKER
1-234-321-5555
11:20A JAN.12 ✓

▶Edit
Save directory
▼▲ ▶=Yes
```

3 While the arrow points to "Edit", press **FWD/EDIT** **▶** (Yes key)

```
FRED PARKER
1-234-321-5555
▼=Next ▶=Edit
```

4 Press **FWD/EDIT** **▶** (Edit key) to select a pattern

•Each time you press **FWD/EDIT** **▶**, the number is rearranged into one of 4 different patterns

- (a) **Phone no.**
- (b) **Area code** - **Phone no.**
- (c) **1** - **Phone no.**
- (d) **1** - **Area code** - **Phone no.**

•The order in which patterns (a)–(d) are displayed depends on how the telephone number is displayed in step 2

(a) 321-5555
▼=Next ▶=Edit

(b) 234-321-5555
▼=Next ▶=Edit

(c) 1-321-5555
▼=Next ▶=Edit

(d) 1-234-321-5555
▼=Next ▶=Edit

5 After editing the number, you can continue with calling back or storing procedures To call back, press **TALK** (p 35)

To store the number in the directory, press **▼** (Next key), and press **FWD/EDIT** **▶** (Save key) (If the caller has no name information, see page 38, from step 3)

```
FRED PARKER
321-5555
▲=Edit ▶=Save
```

•The number edited in step 4 will not be maintained in the Caller List



With the base unit

1 Press **▼** or **▲** to enter the Caller List

5 new calls
▼▲ ▶=Directory

2 Press **▼** or **▲** repeatedly to find the desired caller

FRED PARKER
1-234-321-5555
11:20A JAN 12 ✓

3 Press **GREETING/EDIT** to select a pattern

•Each time you press **GREETING/EDIT**, the number is rearranged into one of 4 different patterns

(a) **Phone no.**

(b) **Area code** - **Phone no.**

(c) 1 - **Phone no.**

(d) 1 - **Area code** - **Phone no.**

•The order in which patterns (a)-(d) are displayed depends on how the telephone number is displayed in step 2

(a) FRED PARKER
321-5555

(b) FRED PARKER
234-321-5555

(c) FRED PARKER
1-321-5555

(d) FRED PARKER
1-234-321-5555

Cordless Telephone



4 After editing the number, you can continue with calling back
Press **DIGITAL SP-PHONE** (p 35)

•The number edited in step 3 will not be maintained in the Caller List

Storing Caller List Information in the Directory

You can store names and phone numbers that are in the Caller List into the directory **Storing must be carried out with the handset.**

Make sure the unit is in the standby mode initially.

1 Press  or  to enter the Caller List

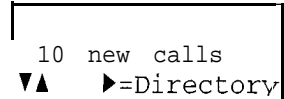

10 new calls
▼▲ ▶=Directory

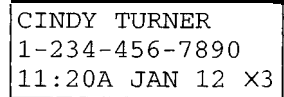

2 Press  or  repeatedly to find the caller you want to store in the directory, and press **FWD/EDIT**  (Yes key)
•If the number requires editing, see page 36

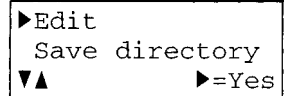

CINDY TURNER
1-234-456-7890
11:20A JAN 12 X3





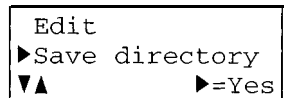

▶Edit
Save directory
▼▲ ▶=Yes

3 Press  or  to select "Save directory", and press **FWD/EDIT**  (Yes key)



Edit
▶Save directory
▼▲ ▶=Yes

If there is no name information for the caller, "Enter name" will be displayed.

- a) If a name is not required, press  (Next key) and press **FWD/EDIT**  (Save key)
- b) If a name is required, enter the name (p 45) When finished, press  (Next key) and press **FWD/EDIT**  (Save key)

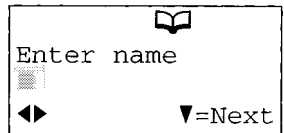

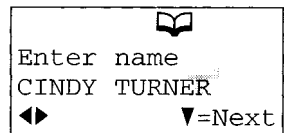

Enter name
◀▶ ▼=Next

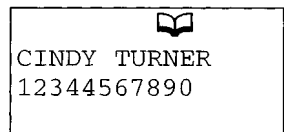

Enter name
CINDY TURNER
◀▶ ▼=Next

- A beep sounds
- To continue storing other items, repeat from step 2
- To return to the standby mode, press **FUNCTION/EXIT/CH**



CINDY TURNER
12344567890

- You can exit the programming mode any time by pressing **FUNCTION/EXIT/CH**
- If the display shows "Directory full" in step 3, press **FUNCTION/EXIT/CH** to exit the list To erase other stored items from the directory, see page 51
- After the maximum of 50 items has been stored, "Directory full" is also displayed
- You cannot store caller information in the directory if a phone number is not displayed

*If 3 beeps sound and the display shows "Save error", move closer to the base unit and start again from step 1



Erasing Caller List Information

After checking the Caller List, you can erase some or all of the entries with the handset or the base unit

Make sure the unit is in the standby mode initially.

To erase a specific caller from the Caller List

With the handset:

- 1 Press **▼** or **▲** to enter the Caller List

```
10 new calls
▼▲ ▶=Directory
```

- 2 Press **▼** or **▲** repeatedly to find the caller you want to erase from the Caller List

```
TOM REAGAN
1-888-777-6666
12:20A JAN 12 ✓
```

- 3 Press **INTERCOM/CLEAR**

```
Clear
```

- A beep sounds and the information is erased
- To erase other items, repeat from step 2
- To return to the standby mode, press **FUNCTION/EXIT/CH**

With the base unit:

- 1 Press **▼** or **▲** to enter the Caller List

```
10 new calls
▼▲ ▶=Directory
```

- 2 Press **▼** or **▲** repeatedly to find the caller you want to erase from the Caller List

```
TOM REAGAN
1-888-777-6666
12:20A JAN.12 ✓
```

- 3 Press **ERASE/CLEAR**

```
Clear
```



- A beep sounds and the information is erased
- To erase other items, repeat from step 2
- To return to the standby mode, press **STOP/EXIT**

➡ Using the Caller List

To erase all entries in the Caller List

Before erasing all entries, make sure that "0 new call" is displayed



With the handset:

- 1 Press  or  to enter the Caller List

```
0 new call
▼▲ ▶=Directory
```

- 2 Press **INTERCOM/CLEAR**

```
▶Exit
All clear
▼▲ ▶=Yes
```

- 3 Press  or  to select "All clear"



```
Exit
▶All clear
▼▲ ▶=Yes
```

- 4 Press **FWD/EDIT**  (Yes key) or **INTERCOM/CLEAR**

```
All clear
```

•A beep sounds and all entries are erased



With the base unit:

- 1 Press  or  to enter the Caller List

```
0 new call
▼▲ ▶=Directory
```

- 2 Press **ERASE/CLEAR**

```
▶Exit
All clear
▼▲ ▶=Yes
```

- 3 Press  or  to select "All clear"

```
Exit
▶All clear
▼▲ ▶=Yes
```

- 4 Press  (Yes key) or **ERASE/CLEAR**

```
All clear
```

•A beep sounds and all entries are erased

One-Touch Dialer



You can store a phone number in the **DIRECT** button of the handset. The stored number is dialed with a one-touch operation.

Storing a Phone Number in the DIRECT Button

Make sure the unit is in the standby mode initially.

- 1 Press **FUNCTION/EXIT/CH**
- 2 Press **▼** or **▲** repeatedly until the arrow points to "Program"
- 3 Press **FWD/EDIT** **▶** (Yes key)
- 4 While the arrow points to "Save DIRECT# Set flash time", press **FWD/EDIT** **▶** (Yes key)
- 5 Enter a phone number, up to 22 digits
 - Each time you press **INTERCOM/CLEAR** the digit to the left of the cursor is erased. To erase all digits, press and hold **INTERCOM/CLEAR**
 - To move the cursor, press **BACK** **◀** or **FWD/EDIT** **▶**
- 6 Press **▼** (Next key)
 - *If you want to edit the entered number, press **▲** (Edit key) and return to step 5
- 7 Press **FWD/EDIT** **▶** (Save key)
 - A beep sounds
 - To return to the standby mode, press **FUNCTION/EXIT/CH**

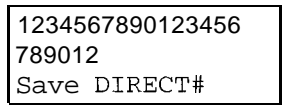
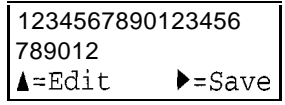
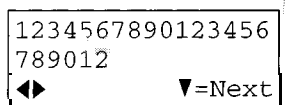
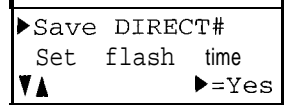
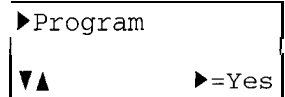

Cordless Telephone

- You can exit the programming mode any time by pressing **FUNCTION/EXIT/CH**
- If a pause is required for dialing, **REDIAL/PAUSE** can be stored in a phone number in step 5. This counts as one digit (p. 54)

Dialing the Stored Number in the DIRECT Button

- 1** Press **[DIRECT]**
*The stored number is displayed

1234567890123456 789012

- 2** Press **[TALK]**
• The number is dialed

Talk 1234567890123456 789012

- You can also dial the stored number by pressing **[TALK]** then pressing **[DIRECT]** (If your line has rotary or pulse service, any access numbers stored after pressing **[TONE]** will not be dialed)

Using the Directory



You can store up to 50 names and phone numbers in the directory using the handset. All directory items are sorted by the first word in alphabetical order. Using the directory, you can make a call by selecting a name on the handset or base unit display.

Storing Names and Numbers in the Directory

Storing must be carried out with the handset. Make sure the unit is in the standby mode initially.

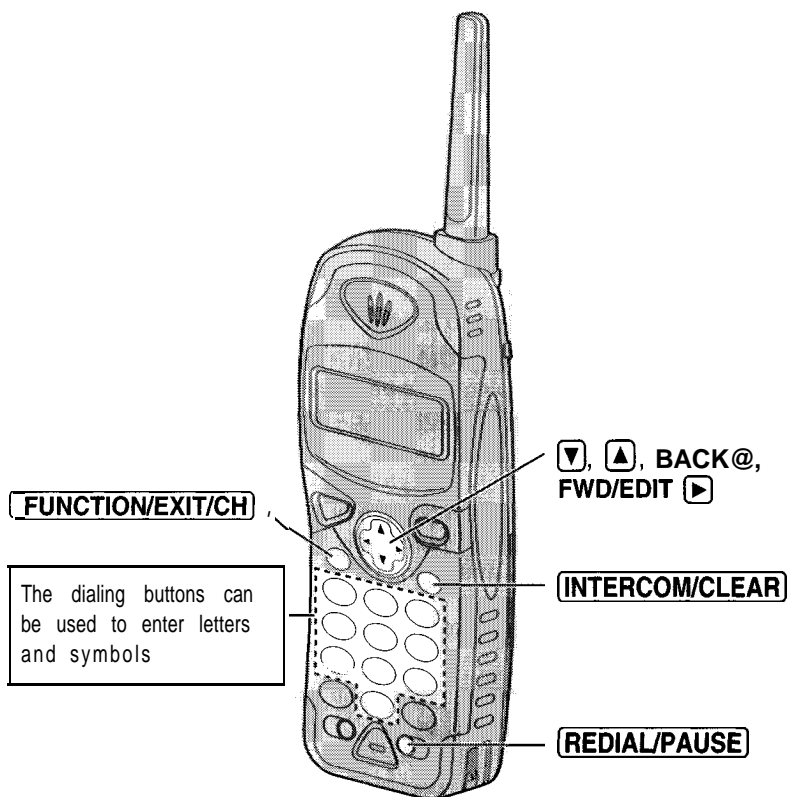

(Continued →)

➡ Using the Directory

1 Press **FUNCTION/EXIT/CH**

```
▶Save directory
  Ringer volume
▼▲ ▶=Yes
```

2 While the arrow points to "Save directory", press **FWD/EDIT** (Yes key)

*The display shows the number of stored items in the directory

```
Directory=
  20 items
```

3 Enter a name, up to 15 characters using the dialing buttons (p 45)

•To move the cursor, press **BACK** or **FWD/EDIT**

•If a name is not required, press (Next key) and go to step 5

```
Enter name
◀▶ ▼=Next
```

```
Enter name
Tom Jones
◀▶ ▼=Next
```

4 Press (Next key)

```
Enter phone no
```

5 Enter a phone number, up to 22 digits

•If you misdial, press **INTERCOM/CLEAR**. Digits are erased from the right. To erase all digits, press and hold **INTERCOM/CLEAR**

```
0987654321
◀▶ ▼=Next
```

6 Press (Next key)

•If you want to change the storing name or number, press (Edit key) repeatedly to reach the desired display and change it

```
Tom Jones
0987654321
▲=Edit ▶=Save
```

7 Press **FWD/EDIT** (Save key)

•A beep sounds

•To continue storing other items, repeat from step 2

•To return to the standby mode, press

FUNCTION/EXIT/CH

```
Tom Jones
0987654321
```

•If a pause is required for dialing, **REDIAL/PAUSE** can be stored in a phone number in step 5. This counts as one digit (p 54)

•You can exit the programming mode any time by pressing

•If the display shows "Directory full" in step 2, press

To erase other stored items from the directory, see page 51

*After the maximum of 50 items has been stored, "Directory full" is also displayed

•If 3 beeps sound and the display shows "Save error", move closer to the base unit and start again from step 1



Selecting Characters to Enter Names

The handset dialing buttons (0 to 9), BACK ◀ and FWD/EDIT ▶ can be used to enter letters and symbols. The letters are printed on the dialing buttons.

Pressing each button selects a character as shown below.

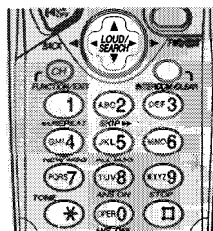

Keys	Number of times key is pressed										
	1	2	3	4	5	6	7	8	9	10	11
1	#	&	'	()	*	,	-		/	1
2	A	B	C	a	b	c	2				
3	D	E	F	d	e	f	3				
4	G	H	I	g	h	i	4				
5	J	K	L	j	k	l	5				
6	M	N	O	m	n	o	6				
7	P	Q	R	S	p	q	r	s	7		
8	T	U	V	t	u	v	8				
9	W	X	Y	Z	w	x	y	z	9		
0	0	Blank									
BACK ◀	To move the cursor to the left										
FWD/EDIT ▶	To move the cursor to the right										

Cordless Telephone

- To enter another character using the same dialing button, press FWD/EDIT ▶ to move the cursor to the next space.







If you make a mistake while entering a name

Use BACK ◀ or FWD/EDIT ▶ to move the cursor to the incorrect character, press **INTERCOM/CLEAR** to delete and enter the correct character. Each time you press **INTERCOM/CLEAR**, a character is erased from the right. To erase all characters, press and hold

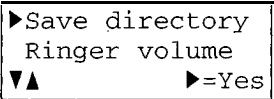
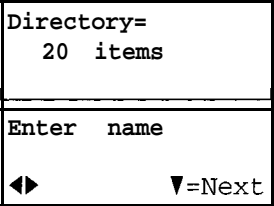
INTERCOM/CLEAR

➔ Using the Directory

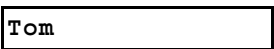
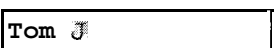
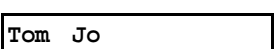
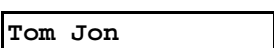
For example, to enter "Tom Jones":

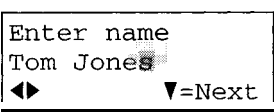
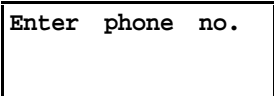
- 1 Press **FUNCTION/EXIT/CH**

- 2 While the arrow points to "save directory", press **FWD/EDIT** (▶) (Yes key)

- 3 Press **8**

- 4 Press **6** six times, then press **FWD/EDIT** (▶) to move the cursor to the right

- 5 Press **6** four times

- 6 Press **FWD/EDIT** (▶) twice to enter a blank

- 7 Press **5**

- 8 Press **6** six times, then press **FWD/EDIT** (▶) to move the cursor to the right

- 9 Press **6** five times

- 10 Press **3** five times

- 11 Press **7** eight times

- 12 When finished, press **▼** (Next key)
•To enter a phone number and continue storing, see page 44, from step 5



Finding Items in the Directory

You can search the directory using the handset or the base unit
Make sure the unit is in the standby mode initially.

With the handset

- 1 Press **BACK** (◀) or **FWD/EDIT** (▶) to enter the directory list

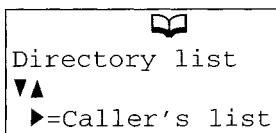

- 2 Press (▼) or (▲)
•The first item is displayed

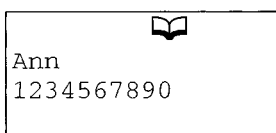

- 3 Press (▼) or (▲) repeatedly until the desired item is displayed
•All directory items are stored in the order shown on the right

To search for a name by initial

- ① Press the dialing button for the first letter of the desired name until any name with the same initial is displayed (see the Index table on page 49)
Ex To find "Frank", press (3) repeatedly until the first item under "F" is displayed
- ② Press (▼) repeatedly until the name is displayed



(▼), (▲), BACK (◀),
FWD/EDIT (▶)
FUNCTION/EXIT/CH

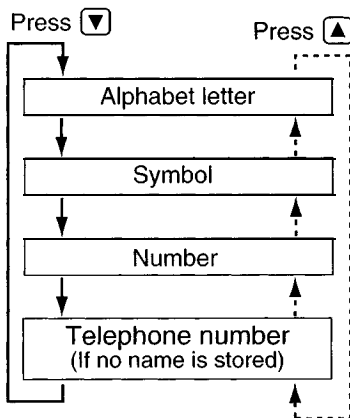

- You can leave the directory list any time by pressing **FUNCTION/EXIT/CH**
- If "No items stored" is displayed in step 2, the directory is empty
- In step 1, you can go to the Caller List by pressing **FWD/EDIT** (▶) (p 34)
- If you are viewing the directory with the handset, another person cannot access the directory using the base unit

➔ Using the Directory

With the base unit

- 1 Press **◀** or **▶** to enter the directory list

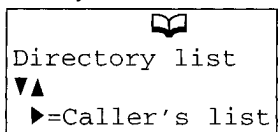

- 2 Press **▼** or **▲**
*The first item is displayed

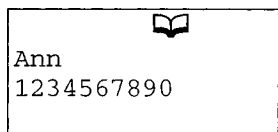

- 3 Press **▼** or **▲** repeatedly until the desired item is displayed

*All directory items are stored in the order shown on the right

To search for a name by initial

- ① Press the dialing button for the first letter of the desired name until any name with the same initial is displayed (see the Index table on page 49)
Ex To find "Frank", press **3** repeatedly until the first item under "F" is displayed

- ② Press **▼** repeatedly until the name is displayed

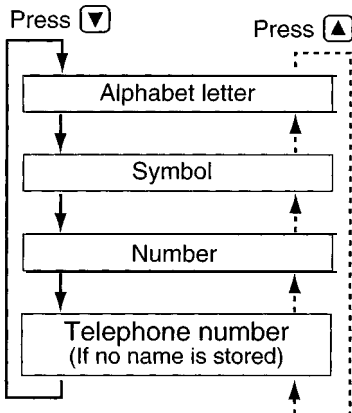
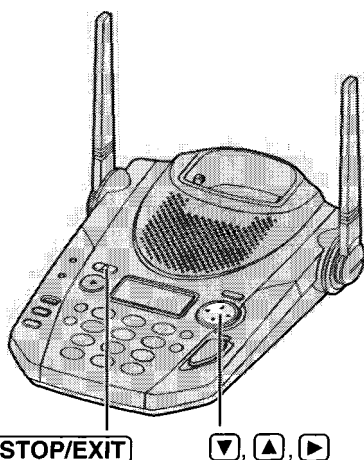

•You can leave the directory list any time by pressing **STOP/EXIT**

*If "no items stored" is displayed in step 2, the directory is empty

•In step 1, you can go to the Caller List by pressing **▶** (p 34)

•If you are viewing the directory with the base unit, another person cannot access the directory using the handset



Index table

Keys	Index	Keys	Index
1	Other symbols, 1	6	M, N, O, 6
2	A, B, C, 2	7	P, Q, R, S, 7
3	D, E, F, 3	8	T, U, V, 8
4	G, H, I, 4	9	W, X, Y, Z, 9
5	J, K, L, 5	0	0

Dialing from the Directory

Make sure the unit is in the standby mode initially.

With the handset

- 1 Press **BACK** or **FWD/EDIT** to enter the directory list

Directory list
 ▼▲
 ▶=Caller's list

- 2 Press or
 - The first item is displayed
- 3 Press or repeatedly to find the directory item that you want to dial
 - To search for the item by initial, see page 47

Frank
 4567890

- To exit the directory, press **FUNCTION/EXIT/CH**

- 4 Press **TALK**
 - The number is dialed automatically

With the base unit

- 1 Press or to enter the directory list

Directory list
 ▼▲
 ▶=Caller's list

- 2 Press or
 - The first item is displayed
- 3 Press or repeatedly to find the directory item that you want to dial
 - To search for the item by initial, see page 48

Frank
 4567890

- To exit the directory, press **(STOP/EXIT)**

- 4 Press **DIGITAL SP-PHONE**
 - *The number is dialed automatically

➔ Using the Directory

Editing an Item in the Directory

Programming must be carried out with the handset.
Make sure the unit is in the standby mode initially.

1 Press **BACK** (◀) or **FWD/EDIT** (▶) to enter the directory list

Directory list
▼▲
▶=Caller's list

2 Press (▼) or (▲)
*The first item is displayed

3 Press (▼) or (▲) repeatedly to find the directory item you want to change, and press **FWD/EDIT** (▶)

Jane
1234567

- To search for the item by initial, see page 47
- If you do not need to change the name, go to step 5

Enter name
Jane
◀▶ ▼=Next

4 Edit the name using the dialing buttons, **BACK** (◀) or **FWD/EDIT** (▶) (p 45), up to 15 characters

Enter name
Jane Walker
◀▶ ▼=Next

5 Press (▼) (Next key)
•If you do not need to change the number, go to step 7

1234567
◀▶ ▼=Next

6 Add a number to the current number
*Pressing **INTERCOM/CLEAR** erases the digit to the left of the cursor To erase all digits, press and hold **INTERCOM/CLEAR**

0981234567
◀▶ ▼=Next

7 Press (▼) (Next key)
•If you want to change the storing name or number, press (▲) (Edit key) repeatedly to reach the desired display and change it

Jane Walker
0981234567
▲=Edit ▶=Save

8 Press **FWD/EDIT** (▶) (Save key)
•A beep sounds
•To continue editing other items, repeat from step 3
•To return to the standby mode, press **FUNCTION/EXIT/CH**

Jane Walker
0981234567

•You can exit the programming mode any time by pressing

FUNCTION/EXIT/CH

Erasing an Item from the Directory

You can erase an item using the handset or the base unit
Make sure the unit is in the standby mode initially.

With the handset

- 1 Press **BACK** (◀) or **FWD/EDIT** (▶) to enter the directory list

Directory list
▼▲
▶=Caller's list

- 2 Press (▼) or (▲)
*The first item is displayed

- 3 Press (▼) or (▲) repeatedly to find the directory item you want to erase
•To search for the item by initial, see page 47

Helen
1234567890

- 4 Press **INTERCOM/CLEAR**
•To stop erasing, press **BACK** (◀) (No key)

Clear?
◀=No ▶=Yes

- 5 Press **FWD/EDIT** (▶) (Yes key) or **INTERCOM/CLEAR**

Clear

- A beep sounds and the item is erased
- To erase other items, repeat from step 3
- To return to the standby mode, press **FUNCTION/EXIT/CH**

With the base unit

- 1 Press (◀) or (▶) to enter the directory list

Directory list
▼▲
▶=Caller's list

- 2 Press (▼) or (▲)
•The first item is displayed

- 3 Press (▼) or (▲) repeatedly to find the directory item you want to erase
•To search for the item by initial, see page 48

Helen
1234567890

- 4 Press **ERASE/CLEAR**
•To stop erasing, press (◀) (No key)

Clear?
◀=No ▶=Yes

- 5 Press (▶) (Yes key) or **ERASE/CLEAR**

Clear

- A beep sounds and the item is erased
- To erase other items, repeat from step 3
- To return to the standby mode, press **STOP/EXIT**

Intercom

A 2-way intercom is possible between the handset and the base unit

Paging the base unit from the handset

1 Handset
Press **INTERCOM/CLEAR**
Talk to the paged party after the beeps
**"Intercom" is displayed

2 Base unit
When the other party's voice is heard, answer using the MIC

3 Handset
To end the intercom, press **INTERCOM/CLEAR**

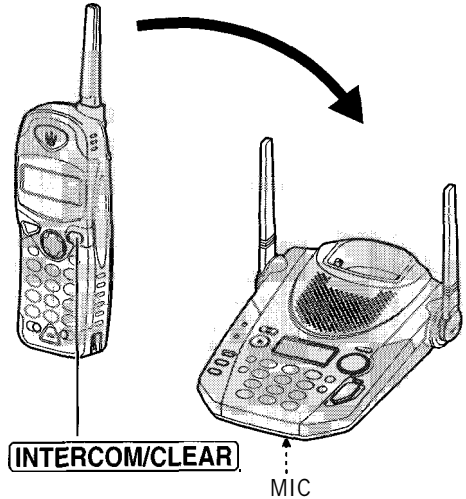

Paging the handset from the base unit (Handset locator)

Using this feature, you can locate a misplaced handset

1 Base unit
Press **LOCATOR/INTERCOM**
**"Paging" is displayed on the base unit
•The handset beeps for 1 minute and "Paging Press INTERCOM" is displayed
•To stop paging, press **LOCATOR/INTERCOM** again

2 Handset
Press **INTERCOM/CLEAR** to answer
**"Intercom" is displayed

3 Base unit
Talk into the MIC

4 Handset
To end the intercom, press **INTERCOM/CLEAR**

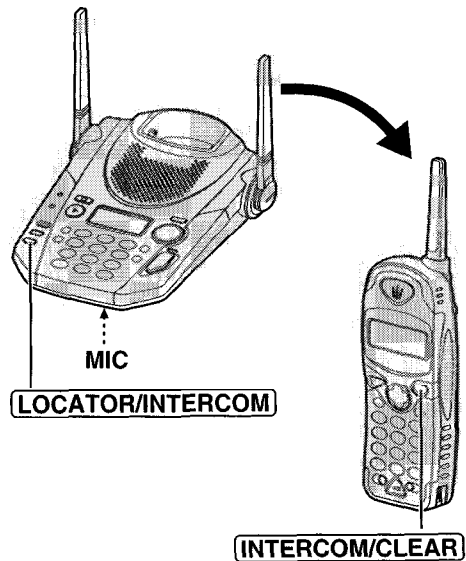

During an intercom call:

*Intercom calls can only be ended with the handset

- If the handset user has difficulty hearing the base unit user, decrease the base unit speaker volume by pressing  on the base unit
- If an incoming call is received, the intercom call stops and the unit starts to ring To answer, press **(TALK)** or **(DIGITAL SP-PHONE)**

Transferring a Call Using the Intercom

The intercom can be used during a call This feature enables you to transfer a call between the handset and the base unit

From the handset to the base unit

- 1 Handset
During a call, press **(INTERCOM/CLEAR)** Talk to the paged party after the beeps

*The call is put on hold and "Intercom hold" is displayed

- If the base unit user does not answer, press **(TALK)**

- 2 Base unit
When the paging party's voice is heard, answer using the MIC

- 3 Base unit
To answer the call, press **(DIGITAL SP-PHONE)**

*The transfer is complete

From the base unit to the handset

- 1 Base unit
During a call, press **(LOCATOR/INTERCOM)**

*The call is put on hold and "Paging" is displayed

- If the handset user does not answer, press **(DIGITAL SP-PHONE)**

- 2 Handset
Press **(INTERCOM/CLEAR)** to answer the page

*"Intercom hold" is displayed

- 3 Handset
To answer the call, press **(TALK)**

*The transfer is complete

Special Features

Automatic Security Code Setting

Each time you place the handset on the base unit, the unit automatically selects one of more than a million security codes. These codes help prevent the unauthorized use of your telephone line by another cordless telephone user.

For Call Waiting Service Users

Press (FLASH/CALL WAIT/PLAYBACK) or (CALL WAIT/FLASH) if you hear a call-waiting tone while talking.

*The first call is put on hold and you can answer the second call.

•To return to the first caller, press FLASH/CALL WAIT/PLAYBACK or (CALL WAIT/FLASH) again.

*The call waiting service cannot be used when

-the answering system is recording someone's message, or

-a parallel connected telephone is in use.

*If this function does not operate properly, consult your telephone company for details.

Call Waiting Caller ID Feature

Call Waiting Caller ID Feature allows your unit to display the second caller's information. After you hear a call-waiting tone while talking, the unit will display the caller's name with the phone number and "----Waiting-----".

NANCY BROWN 1-000-222-3333 ----Waiting-----

*Please contact your telephone company for details and availability in your area.

How to Use the PAUSE Button (For Analog PBX Line/Long Distance Service Users)

We recommend you press (REDIAUPAUSE) if a pause is required for dialing with a PBX or to access a long distance service.

Ex Line access number (9) (PBX)

(9) → (REDIAUPAUSE) → | Phone number

*Pressing (REDIAUPAUSE) once creates a 3.5 second pause. This prevents misdialing when you redial or dial a stored number.

*Pressing (REDIAUPAUSE) more than once increases the length of the pause between numbers.

Temporary Tone Dialing

(For Rotary or Pulse Service Users)

Press **[TONE]** before entering access numbers which require tone dialing

- The dialing mode changes to tone You can enter numbers to access an answering service, electronic banking service, etc When you hang up, the mode will return to pulse

*Access numbers entered after pressing **[TONE]** will not be included when redialing

FLASHButton

Pressing **[FLASH/CALL WAIT/PLAYBACK]** or **[CALL WAIT/FLASH]** allows you to use special features of your host PBX such as transferring an extension call or accessing special telephone services (optional) such as call waiting

Selecting the flash time

The flash time depends on your telephone exchange or host PBX You can select the following flash times "700, 600, 400, 300, 2.50, 110, 100 or 90 ms (milliseconds)" Your phone comes from the factory set to "**700 ms**" **Make sure the unit is in the standby mode initially.**

- 1 Press **[FUNCTION/EXIT/CH]**
- 2 Press **[▼]** or **[▲]** repeatedly until the arrow points to "Program", and press **FWD/EDIT [▶]** (Yes key)

- 3 Press **[▼]** or **[▲]** repeatedly until the arrow points to "Set flash time", and press **FWD/EDIT [▶]** (Yes key)

```
Save DIRECT#
▶Set flash time
▼▲                               ▶=Yes
```

- 4 Press **[▼]** or **[▲]** repeatedly until the desired time is displayed, and press **FWD/EDIT [▶]** (Save key)

```
Flash time
:700ms
▼▲                               ▶=Save
```

- A beep sounds

•To return to the standby mode, press **[FUNCTION/EXIT/CH]**

- You can exit the programming mode any time by pressing

[FUNCTION/EXIT/CH]

*If you are connected via a PBX, a longer flash time may be necessary to use PBX functions (transferring a call etc) Consult your PBX supplier for the correct setting

Automatic Answering Operation

When the unit answers a call, a greeting message is played and the caller's message is recorded. While recording, "- Answering -" will flash on the base unit display.

- The total recording time (including greeting message) is about **15 minutes**. If messages are recorded in noisy rooms, the time may be shortened by up to 3 minutes.
- A maximum of 64 messages (including greeting message) can be recorded.

Setting the Unit to Answer Calls

Press **ANSWER ON** to turn on the answering system.

*The indicator lights and "Answer set" is heard.

*The unit will announce the remaining recording time if it is less than 5 minutes.

*If you hear "Memory full", "Message full" is displayed on the base unit and the ANSWER ON indicator flashes rapidly, erase some, or all, of the messages (p. 59).

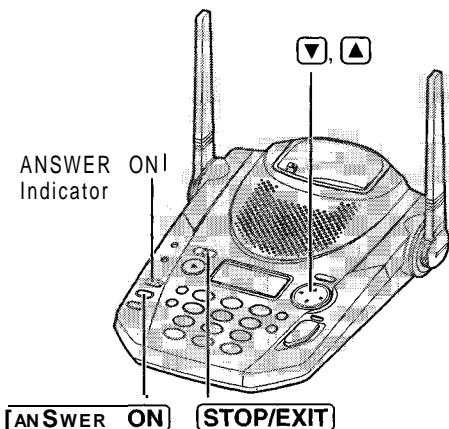

*If you do not want the unit to answer calls, press **ANSWER ON** again to turn off the answering system. The indicator light goes out and "Answer off" is heard.

• You can also turn on the answering system remotely using any other phone (p. 65).

Monitoring incoming calls

While a call is being recorded, you can monitor it through the base unit speaker.

To answer the call with the base unit, press **DIGITAL SP-PHONE**. For the handset, press **TALK**. The unit stops recording.

If the call monitoring feature is not required, turn it off by pressing and holding **STOP/EXIT** in the standby mode. Each time you press and hold **STOP/EXIT** in the standby mode, the feature will turn on or off.

While a call is being recorded, you can turn the feature ON by pressing **▼** or **▲**.

Listening to Messages



You can see the total number of recorded messages on the base unit display. If the ANSWER ON indicator flashes, new messages have been recorded.

Listening to only new messages

Press **[NEW MESSAGE]** briefly.

*The unit announces the number of new messages and plays them back.

Listening to all recorded messages

Press and hold **[NEW MESSAGE]** until playback starts.

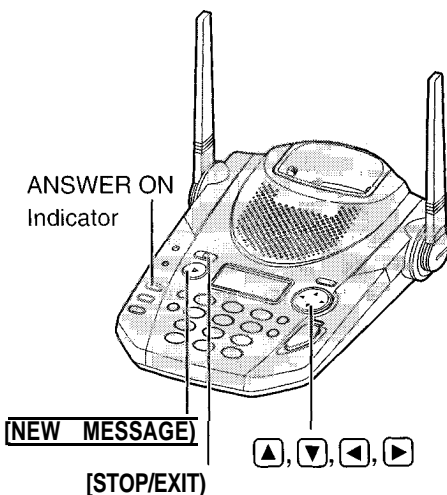

To adjust the speaker volume:

9 levels (0-8) are available while using the answering system. To increase, press **[▲]**.

To decrease, press **[▼]**.

- During each message playback, the message number is displayed. (Ex. While the first message is being played back, “- Message 1 -” is displayed.)
- At the end of the last message, “End of final message” is heard. The unit will announce the remaining recording time if it is less than 5 minutes.

During playback

To repeat message	To repeat from the beginning of the message Press [◀] • If you press within 5 seconds of playback, the previous message will be played.
To skip message	To skip to the next message Press [▶]
To stop operation	Press [STOP/EXIT] • To resume playback, press [NEW MESSAGE] • If you do not press any button for 60 seconds or if you press [STOP/EXIT] again, the unit will return to the standby mode.

➔ Listening to Messages

For Caller ID service users (p 32)

During playback, the base unit display will show the name and/or number of the caller whose message is being played

JACK SMITH 1-222-333-4444 - Message 3 -

To call back the displayed number:

During playback, lift the handset and press **[TALK]** within 10 seconds, or press **[DIGITAL SP-PHONE]**

- The unit stops playback and automatically dials the displayed phone number

*After listening to new incoming messages, "√" will be added to the call entries in the Caller ID Caller List (p 35)

From the Handset

If someone else is in the room and you want to listen to the recorded messages privately, you can use the handset

1 Handset

Press **[FLASH/CALL WAIT/PLAYBACK]**

- The number of new messages is heard on the handset

2 Base unit

To listen to new messages, press **[NEW MESSAGE]** briefly To listen to all messages, press and hold **[NEW MESSAGE]** until playback starts

*The messages will be heard on the handset

- [◀]**, **[▶]** and **[STOP/EXIT]** can also be used during playback (p 57)



3 When finished, press **[FLASH/CALL WAIT/PLAYBACK]** or place the handset on the base unit

- You can also listen to messages without using the base unit See page 66

Erasing Messages

The unit will announce the remaining recording time after playback, if it is less than 5 minutes. New messages cannot be recorded when

-“Memory full” is heard

-“Message full” flashes on the base unit display

-the ANSWER ON indicator flashes rapidly

Erase some, or all, of the messages. We recommend you erase unnecessary messages after each playback.

Erasing a specific message

Press **ERASE/CLEAR** while the message you want to erase is being played.

- The unit erases the message.
- A short beep will sound and the unit will continue to play the next message.

Erasing all messages

All recorded messages, except the greeting message, can be erased at one time.

- 1 Press **ERASE/CLEAR**
 - “Press ERASE again to erase all messages” is heard.
- 2 Within 5 seconds, press **ERASE/CLEAR** again
 - A beep sounds and “No messages” is heard.
 - The base unit display shows “0 message”.

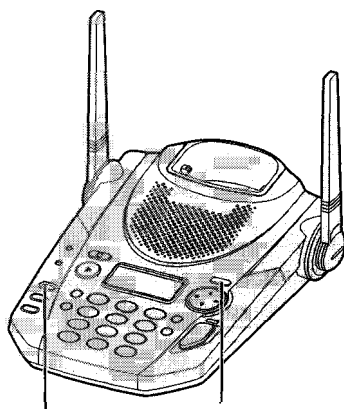

ANSWER ON
Indicator

ERASE/CLEAR

- The information in the Caller List will not be erased. To erase Caller List information, see page 39.

Remote Operation from a Touch Tone Phone

You can operate the answering system from any touch tone phone
A synthesized voice menu will guide you on how to operate the unit
(P 62)

- To skip the voice menu and operate the unit directly, see page 64

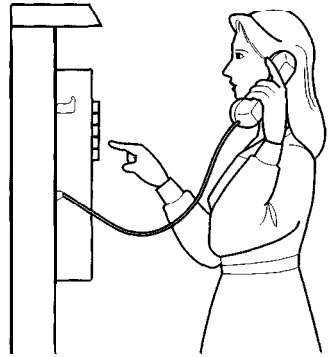

Summary of remote operation

Call your unit from a touch tone phone



Enter your remote code (p 61) during or after the greeting message
*The number of new messages is heard



After 3 seconds, the voice menu will start (p 62)
Follow the menu or enter the direct commands (p 64)



To end remote operation, hang up
*The messages are saved

- The unit will announce the remaining recording time after playback, if it is less than 5 minutes



Setting the Remote Code

The remote code prevents unauthorized people from accessing your unit and listening to your messages. Choose any **2-digit number (00-99)**. The factory preset remote code is "11". If you do not program your own remote code, you can use "11".

Use the handset near the base unit. Make sure the unit is in the standby mode initially.

1 Press **FUNCTION/EXIT/CH**

2 Press **▼** or **▲** repeatedly until the arrow points to "Program"

▶Program
▼▲ ▶=Yes

3 Press **FWD/EDIT** **▶** (Yes key)

▶Save DIRECT# Set flash time
▼▲ ▶=Yes

4 Press **▼** or **▲** repeatedly until the arrow points to "TAD program"

Talk switching
▶TAD program
▼▲ ▶=Yes

5 Press **FWD/EDIT** **▶** (Yes key)
•The base unit display shows programming options

Answering system setting See base unit
--

6 Press **1**
•The current remote code is displayed on the base unit

Base unit display
Remote code : 11

7 Enter a remote code using a **2-digit number (00-99)**

8 Press **FWD/EDIT** **▶** (Save key)

- A beep sounds
- To return to the standby mode, press **FUNCTION/EXIT/CH**

•If 6 beeps sound during programming, a wrong key was pressed. Enter the correct number.

To check the remote code

Repeat steps 1 to 6

•The current remote code is displayed on the base unit. When finished, press **FUNCTION/EXIT/CH**

Answering System

➔ Remote Operation from a Touch Tone Phone

VoiceMenu

The shaded boxes are voice prompts

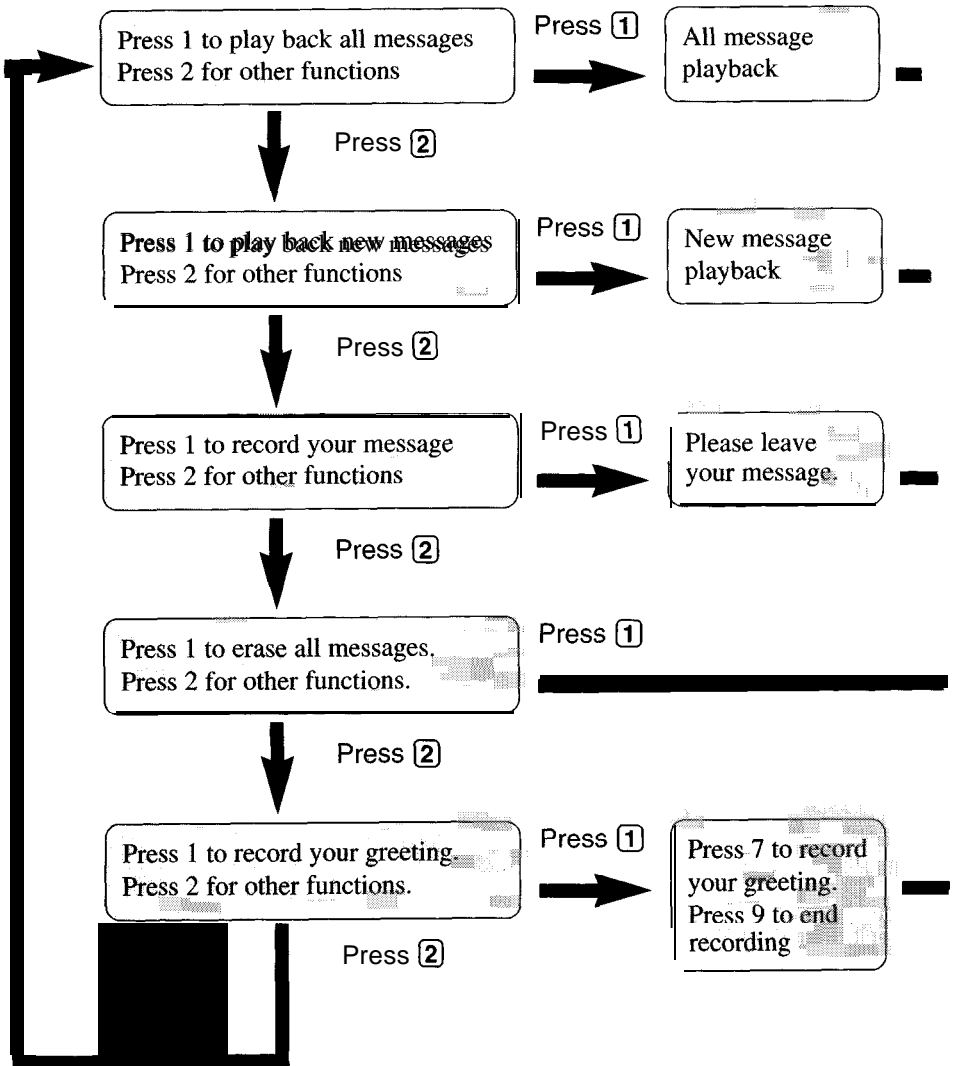



All Message Playback

All recorded messages are played back At the end of the last message, “End of final message” is heard The unit will announce the remaining recording time if it is less than 5 minutes



New Message Playback

Only new messages are played back At the end of the last message, “End of final message” is heard The unit will announce the remaining recording time if it is less than 5 minutes



Recording a Memo Message

You can leave a personal message

- 1 Talk after you hear “Please leave your message”
- 2 When you finish recording, hang up



Erasing All Messages

All recorded messages (except greeting message) are erased



Recording a Greeting Message

You can re-record your greeting message

- 1 Press **7**
You will hear a voice prompt followed by a long beep
- 2 After the beep, talk for up to 2 minutes
- 3 When you finish recording, press **9**
- 4 Your greeting will be played back for confirmation

- 3 seconds after playback, the voice menu will start again from the beginning
- If you hear “Memory full” after playback, erase some, or all, of the messages (p 64)

➔ Remote Operation from a Touch Tone Phone

Direct Remote Operation

Once you have entered the remote code, you can also control your unit by direct commands instead of using the voice menu. To end the remote operation, hang up anytime.

Direct commands

NEW MESSAGE PLAY BACK	4	*Only new messages are played back
ALL MESSAGE PLAY BACK	5	•All messages are played back
REPEAT (During playback)	1	•The current message is repeated
SKIP (During playback)	2	•The current message is skipped The next message is played
STOP	9	• operation is stopped temporarily •To resume operation, enter a direct command within 15 seconds, or the voice menu will start
GREETING MESSAGE RECORDING	7 ↓ RECORD ↓ 9	•A long beep sounds *After the beep, talk immediately for up to 2 minutes •The recording is stopped •The recorded message is played
ERASING A SPECIFIC MESSAGE (During playback)	* 4	•The current message is erased •A short beep will sound and the next message will be played
ERASING ALL MESSAGES	* 5	•All recorded messages are erased •A long beep sounds and “No messages” is heard



- The unit hangs up and will not answer calls until turned on again
-

Turning on the answering system

Call your unit and wait for 15 rings

- The unit will answer and the greeting message will be played
- The answering system will turn on Hang up or enter the remote code for other options
- When turning on the answering system using a rotary or pulse service telephone, you cannot enter the remote code for other options

Skipping the greeting message

After calling your unit, press  during the greeting message

- The unit skips the rest of the greeting message and you can start recording your message after the long beep

Remote Operation with the Handset

You can operate your answering system with the handset

The announcements and recorded messages can only be heard with the handset

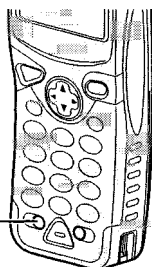

Summary of remote operation

Press **FLASH/CALL WAIT/PLAYBACK**

- The number of new messages is heard
- *"Remote operation" is displayed on the handset



Enter the desired direct commands (p 67)

- If you do not enter a command, the voice menu will start (see below)
- *After the voice menu, all message playback will start.



To end remote operation, press **FLASH/CALL WAIT/PLAYBACK**

- The messages are saved

*The unit will announce the remaining recording time after playback, if it is less than 5 minutes

*If the unit starts to ring during the remote operation, press **TALK** to answer the call. The remote operation is ended.

*If you hear "Memory full" after playback, erase some, or all, of the messages (p 67)

Voice menu

If no commands are entered after you press **FLASH/CALL WAIT/PLAYBACK**, the unit will start the following voice menu

"Press 4 to play back new messages Press 5 to play back all messages"

- You can enter direct commands even if the voice menu has started

Direct commands

NEW MESSAGE PLAY BACK	4	*Only new messages are played back
ALL MESSAGE PLAY BACK	5	•All messages are played back
REPEAT (During playback)	1	•The current message is repeated •You can also press BACK ◀ to repeat a message
SKIP (During playback)	2	•The current message is skipped The next message is played •You can also press FWD/EDIT ▶ to skip a message
STOP	9	*Operation is stopped temporarily •To resume operation, enter a direct command within 15 seconds, or the voice menu will start (p 66)
ERASING A SPECIFIC MESSAGE (During playback)	* 4	•The current message is erased •A short beep will sound and the next message will be played
ERASING ALL MESSAGES	* 5	•All recorded messages are erased •A long beep sounds and “No messages” is heard
ANSWERING SYSTEM OFF	0	*“Answer off” is heard and the answering system is turned off
ANSWERING SYSTEM ON	8	*“Answer set” is heard and the answering system is turned on

Wall Mounting

This unit can be mounted on a wall phone plate

1 Adjust the angle of the cradle

- ① Slide the lock switch to "RELEASE"
- @ Rotate the cradle 90° until it faces straight up
- ③ Slide the lock switch to "LOCK" with the cradle facing straight up

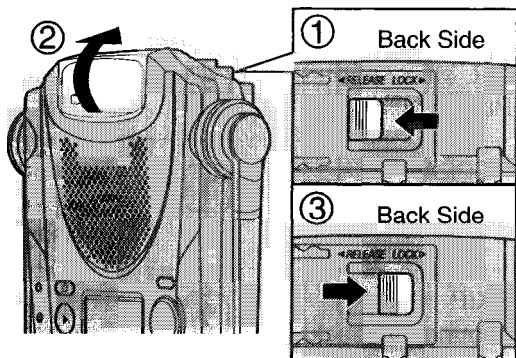

2 Connect the AC adaptor

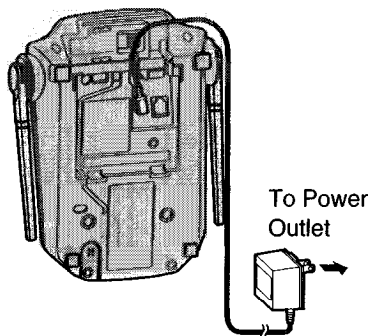

- ## 3
- @ Tuck the telephone line cord inside the wall mounting adaptor
 - @ Connect the telephone line cord to the unit
 - ③ Install the adaptor by pushing it in the direction of the arrow
 - The word "UP" should face upward

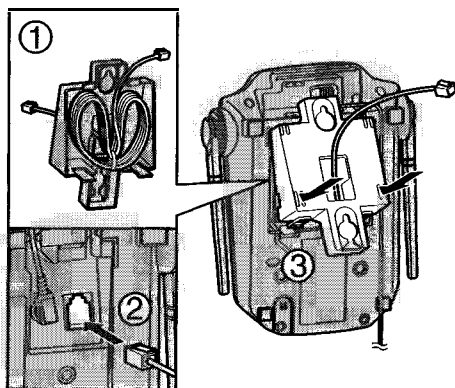

- 4** Connect the telephone line cord. Mount the unit, then slide down.
*Raise the antennas

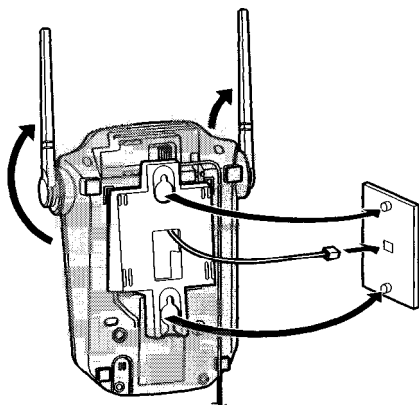

- 5** **To charge the handset battery:**
Place the handset in the cradle as shown.
*The IN USE/CHARGE indicator lights

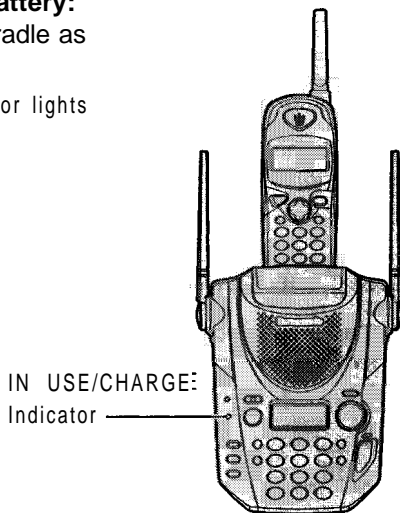

Using the Belt Clip

You can hang the handset on your belt or pocket using the belt clip

To attach the belt clip

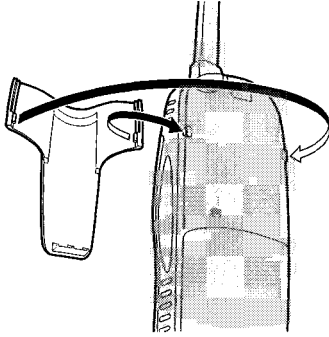

To remove the belt clip

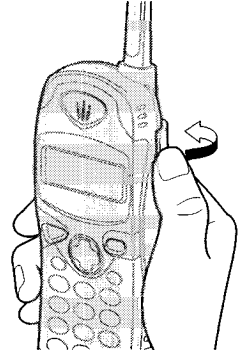

Using an Optional Headset

Plugging an optional headset into the handset allows a hands-free phone conversation. Please use only the Panasonic KX-TCA88 headset. To order, call the accessories telephone number on page 2.

Connecting the headset to the handset

Open the headset jack cover, and connect the headset to the headset jack as shown below.

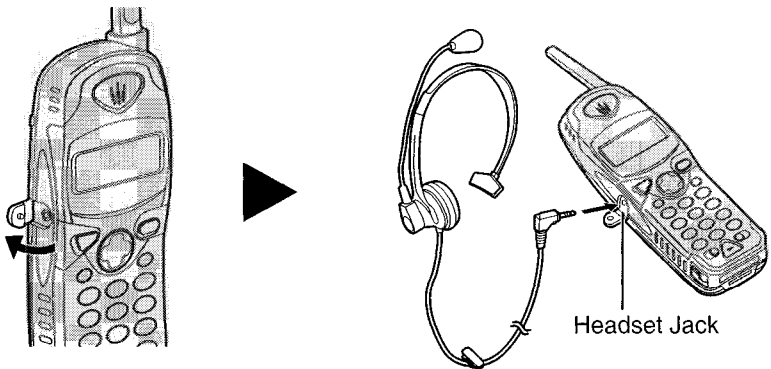

When the optional headset is connected to the handset, make sure to use the headset to talk with the caller. If you want to have a normal cordless phone conversation, disconnect the headset.

Battery Replacement

If "Recharge battery" is displayed and/or "[■ 1" flashes after being fully charged, replace the battery with a new Panasonic P-P510 (N4HKGMB00001) battery To order, call the accessories telephone number on page 2

- 1 **Carefully** insert a flat metal object in the slot, and push forward to release the lock Remove the handset cover

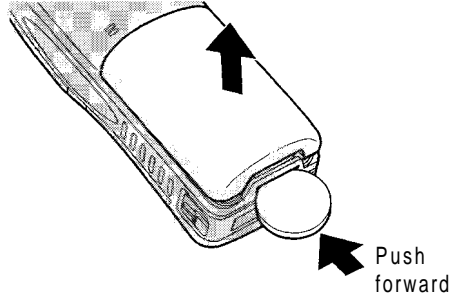

- 2 Replace the battery Then place the battery leads inside the groove, otherwise the leads may be damaged when closing the cover

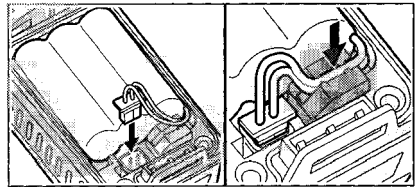

- 3 Close the cover

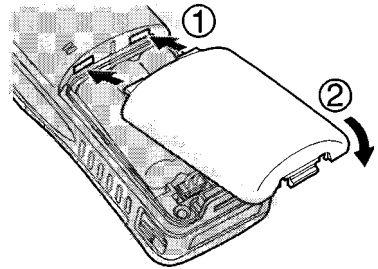

- 4 Make sure you charge the new battery for about 6 hours in order to display the battery strength prompt correctly (p 11)

Attention:

The product you have purchased is powered by a nickel cadmium battery which is recyclable At the end of its useful life, under various state and local laws, it is illegal to dispose of this battery into your municipal waste stream Please call 1-800-8-BATTERY for information on how to recycle this battery



If the Following Appear...

If the unit detects a problem, one of the following messages will be displayed on the handset or the base unit

Handset display

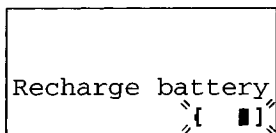

The battery needs to be charged Place the handset on the base unit to charge the battery (P 11)

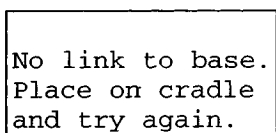

The handset has lost communication with the base unit Place the handset on the base unit and try again

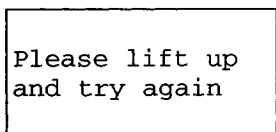

▼, **▲**, **BACK** **◀** or **FWD/EDIT** **▶** was pressed with the handset while the handset was on the base unit Lift the handset and press the button again

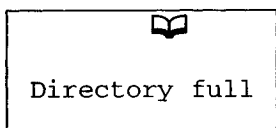

When trying to store an item or Caller List information in the directory, the directory memory is full (p 38, 44) To erase other stored items from the directory, see page 51

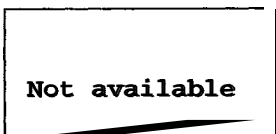

While the base unit was not in the standby mode, **▼** or **▲** was pressed to search the Caller List/directory list, **FWD/EDIT** **▶** was pressed to select an option, or **INTERCOM/CLEAR** or **FLASH/CALL WAIT/PLAYBACK** was pressed

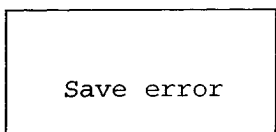

While storing items in the directory, the handset has lost communication with the base unit Move closer to the base unit and try again

Base unit display

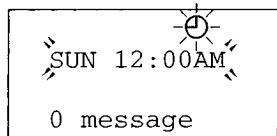

When the clock needs adjusting, the day and time flashes with "⌚" Adjust the clock (p 22)

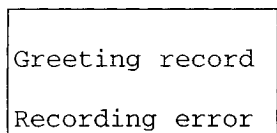

Your greeting message was not recorded correctly Record it again (p 19)

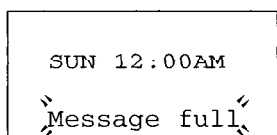

If message memory is full, 'Message full' will flash Erase some, or all, of the messages (p 59)

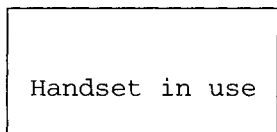

The display will be shown when the handset is in use (making/answering a call, viewing the Caller List or directory list, listening to messages, etc)

Before Requesting Help

Cordless Telephone

Problem	Remedy
"No link to base. Place on cradle and try again." is displayed and an alarm tone sounds	<ul style="list-style-type: none">• You are too far from the base unit Move closer and try again* Place the handset on the base unit and try again* Plug in the AC adaptor* Raise the base unit antennas
Static, sound cuts in/out, fades Interference from other electrical units	<ul style="list-style-type: none">* Locate the handset and the base unit away from other electrical appliances (P 3)* Move closer to the base unit* Raise the base unit antennas• Press FUNCTION/EXIT/CH to select a clearer channel
The handset and/or the base unit do not ring	<ul style="list-style-type: none">• The ringer volume is set to OFF Set to HIGH or LOW (p 17, 18)
The handset display is blank	<ul style="list-style-type: none">• The handset is in the standby mode (p 9) Press ▼, ▲, BACK ◀ or FWD/EDIT ▶ to turn the display on
The handset display is still blank after pressing ▼ , ▲ , BACK ◀ or FWD/EDIT ▶	<ul style="list-style-type: none">• Charge the battery fully (p 11)
You cannot store a name and phone number in the directory	<ul style="list-style-type: none">• You cannot store an item in the directory while the unit is in the talk, speakerphone or intercom mode, or while the answering system is in use• Do not pause for over 60 seconds while storing
While programming or searching, the unit starts to ring and stops the program/search	<ul style="list-style-type: none">• TO answer the call, press TALK or (DIGITAL SP-PHONE) Start again from the beginning after hanging up



Problem	Remedy
The unit does not display the caller's name and/or phone number	<ul style="list-style-type: none">• You need to subscribe to a Caller ID service from a telephone company• Other telephone equipment may be interfering with your phone Disconnect it and try again• Other electrical appliances connected to the same outlet may be interfering with the Caller ID information*Telephone line noise may be affecting the Caller ID information
The handset or base unit display goes to the standby mode while viewing the Caller List	<ul style="list-style-type: none">• Do not pause for over 60 seconds while searching
When a second call is received during a conversation, the unit does not display the new caller's name and/or phone number	<ul style="list-style-type: none">• The line mode selection is incorrect See page 14
You cannot page the handset or the base unit	<ul style="list-style-type: none">• The handset is too far from the base unit• The handset or the base unit is engaged in an outside call, viewing the Caller List/directory list or listening to messages Try again later If you are using the base unit, wait until "Handset in use" disappears
You cannot redial by pressing REDIAL/PAUSE	<ul style="list-style-type: none">• If the last number dialed was more than 32 digits long, the number will not be redialed correctly• Access numbers entered after pressing TONE will not be included when redialing• The button has a double function as either redial or pause It will redial the last number dialed if pressed at the outset of a call (p 26, 29) If another number has been dialed first, it will operate as a pause button (p 54)

➡ Before Requesting Help

Problem	Remedy
You cannot have a conversation using the headset	*When the headset is connected (p 70), you must use the headset to talk with the caller To have a normal cordless phone conversation, disconnect the headset
You cannot have a conversation using the headset	*Make sure that the headset is connected properly (p 70)

Answering System

Problem	Remedy
The answering system is on, but incoming messages are not recorded	<ul style="list-style-type: none">•The recording time is set to "Greeting only" Select "1 minute" or "3 minutes" (p 24)*Memory is full Erase some, or all, of the messages (p 59)
You cannot listen to the recorded messages	*Make sure that the unit is in the standby mode
'Message full" flashes on the base unit display and the ANSWER ON indicator flashes rapidly, and no new messages are recorded.	*Memory is full Erase some, or all, of the messages (p 59)
You cannot operate the answering system at the base unit	<ul style="list-style-type: none">•The handset user is operating the answering system, or is engaged in an outside call Wait until "Handset in use" disappears
You cannot operate the answering system from a touch tone phone	<ul style="list-style-type: none">•Make sure you enter the correct remote code•The answering system may not respond if the tones are too short to activate the unit Press each button firmly● The answering system is off Turn it on (p 65)



Problem	Remedy
You cannot operate the answering system with the handset	<ul style="list-style-type: none">•Someone is operating the answering system•You are too far from the base unit Move closer to the base unit•The unit is recording a message To answer the call, press TALK
While recording a greeting message, the unit starts to ring and stops recording	<ul style="list-style-type: none">•To answer the call, press DIGITAL SP-PHONE or press TALK Start again from the beginning after hanging up
During playback, the unit starts to ring and stops playback	<ul style="list-style-type: none">•To answer the call, press DIGITAL SP-PHONE or press TALK To resume playback, press NEW MESSAGE after hanging up
The base unit does not display the name and/or number of the caller whose message is being played	<ul style="list-style-type: none">•If the caller is not stored in the Caller List, the base unit will not display the caller's information

➔ Before Requesting Help

General

Problem	Remedy
The unit does not work	<ul style="list-style-type: none">● Check the settings (p 10-14)*Charge the battery fully (p 11)● Clean the charge contacts and charge again (p 12)*Install the battery properly (p 71)● Place the handset on the base unit and unplug the AC adaptor to reset Plug in, and try again● Re-install the battery and place the handset on the base unit (p 71) Try again
You cannot program items, such as the dialing mode	<ul style="list-style-type: none">*Programming is not possible while the unit is in the talk or speakerphone mode, when viewing the Caller List/directory list, or while the answering system is in use● Do not pause for over 60 seconds while programming*Move closer to the base unit*Make sure that the unit is in the standby mode
Previously programmed information is erased	<ul style="list-style-type: none">● If a power failure occurs, programmed information may be erased Reprogram if necessary
"Recharge battery" is displayed on the handset, "[]" flashes or the unit beeps intermittently	<ul style="list-style-type: none">● Charge the battery fully (p 11)
You charged the battery fully, but "Recharge battery" is still displayed and/or "[]" continues to flash	<ul style="list-style-type: none">● Clean the charge contacts and charge again (p 12)● Install a new battery (p 71)

Problem

Remedy

The IN USE/CHARGE indicator light does not go out while charging

•This is normal

If you cannot solve your problem

•Call our customer call center at 1-800-21 1 -PANA(7262)

*Panasonic's e-mail address for customer inquiries
consumerproducts@panasonic.com
for customers in the USA or Puerto Rico
ONLY

Adding Another Phone

This unit will not function during a power failure To connect a standard telephone on the same line, use the Panasonic T-adaptor KX-J66 To order, call the accessories telephone number on page 2

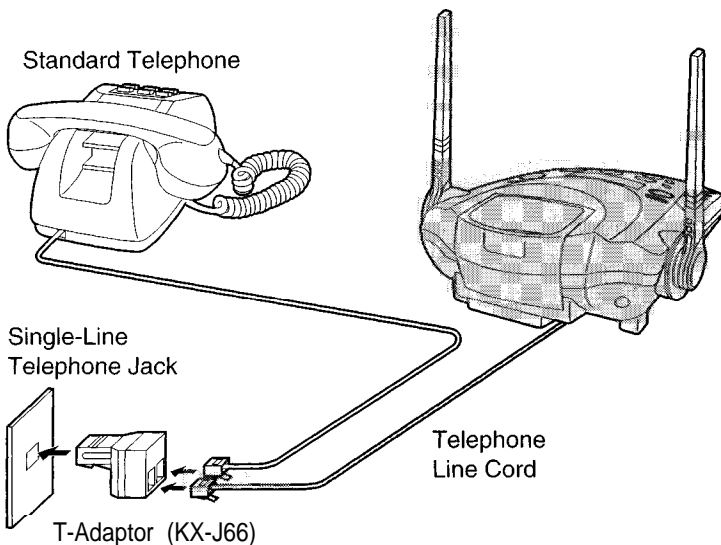

Important Safety Instructions

When using this unit, basic safety precautions should always be followed to reduce the risk of fire, electric shock, or personal injury

- 1 Read and understand all instructions
- 2 Follow all warnings and instructions marked on this unit
- 3 Unplug this unit from AC outlets before cleaning Do not use liquid or aerosol cleaners Use a damp cloth for cleaning
- 4 Do not use this unit near water, for example, near a bathtub, washbowl, kitchen sink, or the like
- 5 Place this unit securely on a stable surface Serious damage and/or injury may result if the unit falls
- 6 Do not cover slots and openings on the unit They are provided for ventilation and protection against overheating Never place the unit near radiators, or in a place where proper ventilation is not provided
- 7 Use only the power source marked on the unit If you are not sure of the type of power supplied to your home, consult your dealer or local power company
- 8 Do not place objects on the power cord Install the unit where no one can step or trip on the cord
- 9 Do not overload wall outlets and extension cords This can result in the risk of fire or electric shock
- 10 Never push any objects through slots in this unit This may result in the risk of fire or electric shock Never spill any liquid on the unit
- 11 To reduce the risk of electric shock, do not disassemble this unit Take the unit to an authorized servicer when service is required Opening or removing covers may expose you to dangerous voltages or other risks Incorrect reassembly can cause electric shock when the unit is subsequently used
- 12 Unplug this unit from the wall outlet and refer servicing to an authorized servicer when the following conditions occur
 - A When the power supply cord or plug is damaged or frayed
 - B If liquid has been spilled into the unit
 - C If the unit has been exposed to rain or water
 - D If the unit does not work normally by following the operating instructions Adjust only controls covered by the operating instructions Improper adjustment may require extensive work by an authorized servicer
 - E If the unit has been dropped or physically damaged
 - F If the unit exhibits a distinct change in performance
- 13 During thunderstorms, avoid using telephones except cordless types There may be a remote risk of an electric shock from lightning
- 14 Do not use this unit to report a gas leak, when in the vicinity of the leak

SAVE THESE INSTRUCTIONS

CAUTION:

To reduce the risk of fire or injury to persons, read and follow these instructions

- 1 Use only the battery(ies) specified
- 2 Do not dispose of the battery(ies) in a fire They may explode Check with local waste management codes for special disposal instructions
- 3 Do not open or mutilate the battery(ies) Released electrolyte is corrosive and may cause burns or injury to the eyes or skin The electrolyte may be toxic if swallowed
- 4 Exercise care in handling batteries in order not to short the battery to conductive materials such as rings, bracelets, and keys The battery and/or conductor may overheat and cause burns
- 5 Charge the battery(ies) provided with or identified for use with this product only in accordance with the instructions and limitations specified in this manual

WARNING:

TO PREVENT FIRE OR SHOCK HAZARD, DO NOT EXPOSE THE BASE UNIT TO RAIN OR ANY TYPE OF MOISTURE ONLY THE HANDSET IS SHOCK AND SPLASH RESISTANT

- The AC adaptor is used as the main disconnect device, ensure that the AC outlet is located/installed near the unit and is easily accessible

Splash-Resistant (HANDSET ONLY)

The handset is designed to be splash resistant

You can use the handset with wet hands

CAUTION:

- Do not immerse in water or leave under running water.
- Keep the handset away from salt water
- Avoid exposure to prolonged high humidity
- Since water in headset jack may cause damage, close the headset jack cover when the optional headset is not in use When the optional headset is connected, do not use the handset with wet hands
- If the handset is wet, wipe with a soft dry cloth
- The base unit is not designed to be splash resistant Do not place the wet handset on the base unit

Shock-Resistant (HANDSET ONLY)

Although the handset is designed to be shock resistant, do not throw or step on the handset

FCC and Other Information

If requested by the telephone company, inform them as follows

FCC Registration No (found on the bottom of the unit)
Ringer Equivalence 0 1B
The particular telephone line to which the equipment is connected

This unit must not be connected to a coin operated line

If you are on a party line, check with your local telephone company

Ringer Equivalence No. (REN):

The REN is useful in determining the quantity of devices you may connect to your telephone line and still have all of those devices ring when your telephone number is called. In most, but not all areas, the sum of the REN's of all devices connected to one line should not exceed five (5.0). To be certain of the number of devices you may connect to your line, as determined by the REN, you should contact your local telephone company to determine the maximum REN for your calling area.

In the event terminal equipment causes harm to the telephone network, the telephone company should notify the customer, if possible, that service may be stopped.

However, where prior notice is impractical, the company may temporarily cease service providing that they

(a) Promptly notify the customer

(b) Give the customer an opportunity to correct the problem with their equipment

(c) Inform the customer of the right to bring a complaint to the Federal

Communication Commission pursuant to procedures set out in FCC Rules and Regulations Subpart E of Part 68

The Telephone Company may make changes in its communications facilities, equipment, operations or procedures, where such action is reasonably required in the operation of its business and is not inconsistent with the rules and regulations in FCC Part 68.

If such changes can be reasonably expected to render any customer terminal equipment incompatible with telephone company communications facilities, or require modification or alteration of such terminal equipment, or otherwise materially affect its use or performance, the customer shall be given adequate notice in writing, to allow the customer an opportunity to maintain uninterrupted service.

When programming emergency numbers and/or making test calls to emergency numbers

- 1 Remain on the line and briefly explain to the dispatcher the reason for the call before hanging up
- 2 Perform such activities in the off-peak hours, such as early morning hours or late evenings

This device complies with Part 15 of the FCC Rules. Operation is subject to the following two conditions: (1) This device may not cause harmful interference, and (2) this device must accept any interference received, including interference that may cause undesired operation.

Privacy of communications may not be ensured when using this phone.

CAUTION:

Any changes or modifications not expressly approved by the party responsible for compliance could void the user's authority to operate this device

Note:

This equipment has been tested and found to comply with the limits for a Class B digital device, pursuant to Part 15 of the FCC Rules. These limits are designed to provide reasonable protection against harmful interference in a residential installation. This equipment generates, uses, and can radiate radio frequency energy and, if not installed and used in accordance with the instructions, may cause harmful interference to radio communications. However, there is no guarantee that interference will not occur in a particular installation. If this equipment does cause harmful interference to radio or television reception, which can be determined by turning the equipment off and on, the user is encouraged to try to correct the interference by one or more of the following measures:

- Reorient or relocate the receiving antenna
- Increase the separation between the equipment and receiver
- Connect the equipment into an outlet on a circuit different from that to which the receiver is connected
- Consult the dealer or an experienced radio/TV technician for help

Some cordless telephones operate at frequencies that may cause interference to nearby TVs and VCRs. To minimize or prevent such interference, the base of the cordless telephone should not be placed near or on top of a TV or VCR. If interference is experienced, move the cordless telephone further away from the TV or VCR. This will often reduce, or eliminate, interference.

Operating near 2.4 GHz electrical appliances may cause interference. Move away from the electrical appliances and/or press the CH (Channel) button.

- **Environment** — do not place the unit in a room where the temperature is less than 5°C (41 °F) or greater than 40°C (104°F). Allow 10 cm (4") clearance around the unit for proper ventilation. Avoid excessive smoke, dust, mechanical vibration, shock, or direct sunlight.
- **Medical** — consult the manufacturer of any personal medical devices, such as pacemakers, to determine if they are adequately shielded from external RF (radio frequency) energy. (The unit operates in the frequency range of 2401 MHz to 2472 MHz, and the power output level can range from 0.001 watts to 0.20 watts.) Do not use the unit in health care facilities if any regulations posted in the area instruct you not to do so. Hospitals or health care facilities may be using equipment that could be sensitive to external RF (radio frequency) energy.
- **Routine care** -wipe the unit with a soft cloth. Do not use benzene, thinner, or any abrasive powder. When you leave the unit unused for a long period of time, unplug the AC adaptor from the outlet.
- **If there is any trouble** — disconnect the unit from the telephone line and connect a known working phone. If the known working phone operates properly, have your unit repaired by one of the authorized Panasonic Factory Service Centers. If the known working phone does not operate properly, consult your telephone company.

For product service

- *Panasonic Servicenters are listed in the servicenter directory
- Call 1-800-21 1 -PANA(7262) for the location of an authorized servicenter
- Panasonic's e-mail address for customer inquiries
consumerproducts@panasonic.com
for customers in the USA or Puerto Rico ONLY

When you ship the product

- *Carefully pack your unit, preferably in the original carton
- Attach a letter, detailing the symptom, to the outside of the carton

Symptom

- Send the unit to an authorized servicenter, prepaid and adequately insured
- Do not send your unit to the Panasonic Consumer Electronics Company listed below or to executive or regional sales offices. These locations do not repair consumer products

- This cordless telephone is designed for use in the United States of America. Sale or use of this product in other countries may violate local laws.
- Ce téléphone sans fil est conçu pour être utilisé aux États-Unis d'Amérique. La vente ou l'emploi de cet appareil dans certains autres pays peut constituer une infraction à la législation locale.
- Este teléfono sin cordón fue elaborado para uso en los Estados Unidos de América. La venta o el empleo de este producto en ciertos países puede constituir violación de la legislación local.
- このコードレス電話機は、日本国外での使用を目的として設計されており、日本国内での使用は法律違反となります。従って、当社では日本国内においては原則として修理などのサービスは致しかねます。

Panasonic Consumer Electronics Company,
Division of Matsushita Electric Corporation of America
One Panasonic Way, Secaucus, New Jersey 07094

Panasonic Sales Company,
Division of Matsushita Electric of Puerto Rico, Inc.
Ave 65 de Infantería, Km 9.5, San Gabriel Industrial Park
Carolina, Puerto Rico 00985

Quick Guide

Please read the Operating Instructions for details.

•Keep this leaflet for future reference.

Check the accessories:

- | | | | |
|--|-----|--|-----|
| <input type="checkbox"/> AC Adaptor | one | <input type="checkbox"/> Wall Mounting Adaptor | one |
| <input type="checkbox"/> Telephone Line Cord | one | <input type="checkbox"/> Belt Clip | one |

How to Set Up the Unit

1 Connect as shown.

Single-Line Telephone Jack

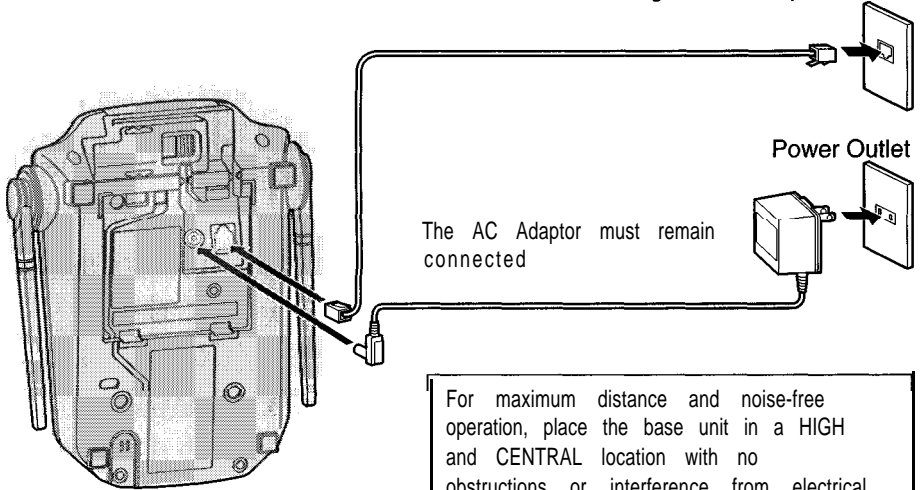

For maximum distance and noise-free operation, place the base unit in a HIGH and CENTRAL location with no obstructions or interference from electrical appliances

2 Charge the battery for about 6 hours before initial use.

Place the handset on the base unit

- The IN USE/CHARGE indicator lights and a beep sounds

IN USE/CHARGE Indicator

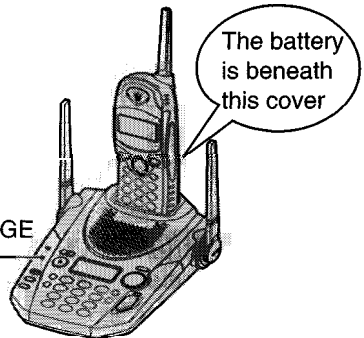

How to Operate the Unit

Raise the base unit antennas for best reception.

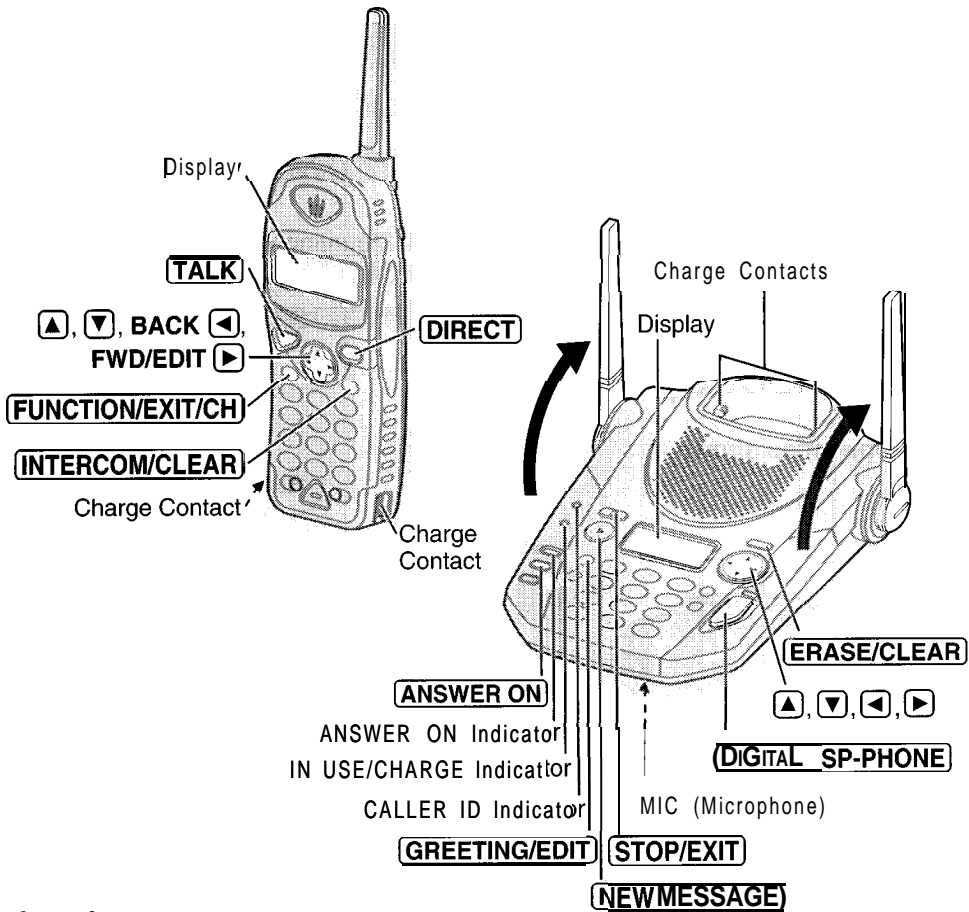

Attention:

*Recharge the battery when

- "Recharge battery" is displayed on the handset,
- "{ | }" flashes on the display, or
- the handset beeps intermittently while it is in use

•Clean the handset and the base unit charge contacts with a soft, dry cloth once a month. Clean more often if the unit is subject to grease, dust or high humidity
Otherwise the battery may not charge properly

Selecting the Dialing Mode

Your phone comes from the factory set to "Tone" If you cannot dial, set to "Pulse" Use the handset near the base unit Make sure the unit is in the standby mode initially

FUNCTION/EXIT/CH → ▼ or ▲ to select "Program" → **FWD/EDIT** ▶ (Yes key)
→ ▼ or ▲ to select "Set dial mode" → **FWD/EDIT** ▶ (Yes key) → ▼ Or ▲
to select "Pulse" or "Tone" → **FWD/EDIT** ▶ (Save key)

Making Calls

With the handset

- 1 Press **TALK**.
 - 2 Dial a phone number
 - 3 To hang up, press **TALK** or place the handset on the base unit.
- To dial after confirming the entered number, enter a phone number and press **TALK**.
 - If noise interferes with the conversation, press **FUNCTION/EXIT/CH** to select a clearer channel or move closer to the base unit.
 - To select the receiver volume, press **▲** or **▼** while talking. 3 levels (HIGH, MEDIUM, LOW) are available. Each time you press, the volume level will change.

With the base unit

- 1 Press **DIGITAL sp-PHONE**.
 - 2 Dial a phone number
 - 3 When the other party answers, talk into the MIC.
 - 4 To hang up, press **DIGITAL SP-PHONE**.
- To select the speaker volume, press **▲** or **▼** while talking. 8 levels are available. Each time you press, the volume level will change.

Answering Calls

With the handset

- Press **TALK**.
- You can also answer a call by pressing any dialing button **0** to **9**, ***** or **#**.
 - If you set the Auto Talk feature to ON, you can answer a call by lifting the handset off the base unit (see page 16 in the Operating Instructions).

With the base unit

Press **DIGITAL SP-PHONE** and talk into the MIC.

One-Touch Dialer

A phone number stored in the **DIRECT** button can be dialed with a one-touch operation.

To store a phone number in the DIRECT button

Use the handset near the base unit. Make sure the unit is in the standby mode initially

FUNCTION/EXIT/CH → **▼** or **▲** to select "Program" → **FWD/EDIT** **▶** (Yes key) → **FWD/EDIT** **▶** (Yes key) while the arrow points to "Save DIRECT#" → **▶** Phone number (up to 22 digits) → **▼** (Next key) → **FWD/EDIT** **▶** (Save key)

To dial a stored number in the DIRECT button

TALK T → _____

- The stored number is dialed.

Using the Directory

You can store up to 50 names and phone numbers in the directory. All directory items are sorted by the first word in alphabetical order. Using the directory, you can make a call by selecting a name on the handset or base unit display.

To store names and phone numbers in the directory

Use the handset near the base unit.

Make sure the unit is in the standby mode initially.

[FUNCTION/EXIT/CH] → **FWD/EDIT** (Yes key) while the arrow points to "Save Directory" → [Name (up to 15 characters)] (See below) • **[Next key]** → **[Phone number (up to 22 digits)]** → **[Next key]** + **FWD/EDIT** (Save key)

To enter names and symbols

The handset dialing buttons (0 to 9), **BACK** (Left arrow) and **FWD/EDIT** (Right arrow) can be used to enter letters and symbols. Each button selects a character as shown below.

Keys	Index	Keys	Index	Keys	Index
1	# & ' () * , - / 1	6	M N O m n o 6	BACK (Left arrow)	To move the cursor to the left
2	A B C a b c 2	7	P Q R S p q r s 7		
3	D E F d e f 3	8	T U V t u v 8		
4	G H I g h i 4	9	W X Y Z w x y z 9	FWD/EDIT (Right arrow)	To move the cursor to the right
5	J K L j k l 5	0	Blank		

- To enter another character using the same dialing button, press **FWD/EDIT** (Right arrow) to move the cursor to the next space.
- If you make a mistake while entering a name, use **BACK** (Left arrow) or **FWD/EDIT** (Right arrow) to move the cursor to the incorrect character, press **[INTERCOM/CLEAR]** to delete and enter the correct character. Each time you press **[INTERCOM/CLEAR]**, a character is erased from the right. To erase all characters, press and hold **[INTERCOM/CLEAR]**.

To dial from the directory

With the handset

- Press **BACK** (Left arrow) or **FWD/EDIT** (Right arrow) to enter the directory list.
 - Press **[Next key]** or **[Up key]**.
 - Press **[Next key]** or **[Up key]** repeatedly to find the desired item.
 - To search for a name by initial: Press the dialing button for the first letter of the desired name until any name with the same initial is displayed. Press **[Next key]** until the name is displayed.
 - Press **[TALK]**.
- To leave the directory list, press **[FUNCTION/EXIT/CH]**.
 - When "►=Caller's list" is displayed, you can go to the Caller List by pressing **FWD/EDIT** (Right arrow) (p. 6).

With the base unit

1 Press **[Left]** or **[Right]** to enter the directory list.

2 Press **[Down]** or **[Up]**.

3 Press **[Down]** or **[Up]** repeatedly to find the desired item.

•To search for a name by Initial: Press the dialing button for the first letter of the desired name until any name with the same initial is displayed. Press **[Down]** until the name is displayed.

4 Press **[DIGITAL SP-PHONE]**.

•To leave the directory list, press **[STOP/EXIT]**.

*When "►=Caller's list" is displayed, you can go to the Caller List by pressing **[Right]** (p. 6).

Caller ID Service

This unit is compatible with a Caller ID service offered by your telephone company. After subscribing, the calling party's information will be displayed after the first ring.

The unit can record information of up to 50 different callers, including the time and date received and the number of times called, in the Caller List. The Caller List information is sorted by the most recent to the oldest call. When the 51st call is received, the first call is deleted.

How caller information is displayed when a call is received

The handset and base unit displays show the caller's name and number after the first ring.

TINA ROBINSON 1-000-222-3333

*After you answer the call, the display will show the length of the call.

*Caller information cannot be displayed in the following cases:

- If the caller dialed from an area which does not provide a Caller ID service, the display will show "Out of area"
- If the caller has requested not to display his/her information, the display will show "Private caller"

To check the number of new calls

When new calls have been received, the CALLER ID indicator flashes slowly on the base unit.

Ex. You have received 10 new calls.

Handset display

10 new calls []

Base unit display

SUN 12 00AM 10 new calls 0 message
--

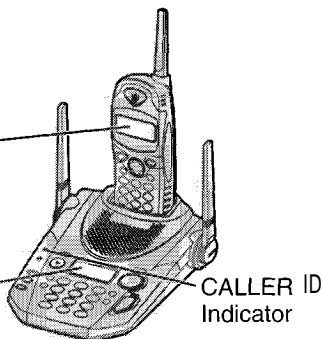

CALLER ID
Indicator

While the handset is off the base unit:

Press **[Down]** or **[Up]** to turn the display on.

The display will show the following:

10 new calls ▼▲ ►=Directory

Viewing the Caller List

You can check who has called as follows.

Ex. When you search from the most recent call:

With the handset

1 Press **▼** or **▲**.

2 Press **▼** repeatedly to find the desired caller

- If there is no name information for a caller, the display will only show the phone number.
- To return to the previous caller, press **▲**.

*When "►=Directory" is displayed, you can go to the directory list by pressing **FWD/EDIT ►** (p. 4).

To exit the Caller List, press

FUNCTION/EXIT/CH.

To call back from the Caller List,

press **TALK** while the desired item is displayed.

- If required, edit the phone number by pressing **FWD/EDIT ►** following the instructions on the display. The phone number will be edited into one of the 4 patterns. (For details, see page 36 in the English Operating Instructions.)

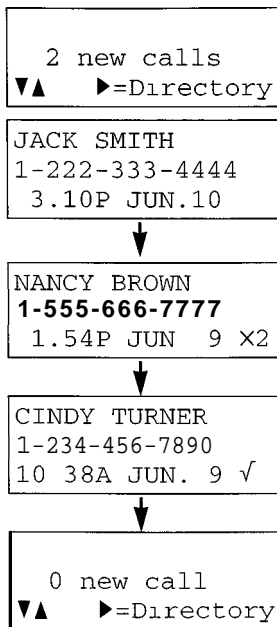

Display meaning:

- ✓ : You have checked this caller information, answered the call, called back the caller or played back the message.
- X2-X9 : The number of times the same caller called (up to 9). After checking, "X2"- "X9" will be replaced with "✓".

With the base unit

1 Press **▼** or **▲**.

2 Press **▼** repeatedly to find the desired caller

- If there is no name information for a caller, the display will only show the phone number
- To return to the previous caller, press **▲**.

*When "►=Directory" is displayed, you can go to the directory list by pressing **►** (p. 5).

To exit the Caller List, press **STOP/EXIT**.

To call back from the Caller List, press **DIGITAL SP-PHONE** while the desired item is displayed.

- If required, edit the phone number by pressing **GREETING/EDIT**. The phone number will be edited into one of the 4 patterns. (For details, see page 37 in the Operating Instructions.)

Preparing the Answering System

You can program the following functions using the handset near the base unit. The base unit display shows programming options or settings. Make sure the unit is in the standby mode initially

① Setting the day/time

FUNCTION/EXIT/CH → **▼** or **▲** to select "Program" →
→ **FWD/EDIT** **▶** (yes key) → **▼** or **▲** to select "TAD program" →
→ **FWD/EDIT** **▶** (yes key) → **0** → **Current time (4-digit number)** →
EX. To set "9:30", press "0930"
→ ***** (to set AM/PM)+ **#** (to set the day) → **FWD/EDIT** **▶** (save key)

• If a power failure occurs, reprogram the current time/day

② Selecting the caller's recording time

Your phone comes from the factory set to "3 minutes" If you select "greeting only", the unit will not record a caller's message.

FUNCTION/EXIT/CH → **▼** or **▲** to select "Program" →
→ **FWD/EDIT** **▶** (Yes key) → **▼** or **▲** to select "TAD program" →
→ **FWD/EDIT** **▶** (Yes key) → **5** → **1-3** → **FWD/EDIT** **▶** (save key)
1: 1 minute
2: 3 minutes
3: greeting only

③ Selecting the number of rings before the unit answers

You can select "2" to "7" or "Toll saver" Your phone comes from the factory set to "Toll saver"

FUNCTION/EXIT/CH → **▼** or **▲** to select "Program" →
→ **FWD/EDIT** **▶** (yes key) → **▼** or **▲** to select "TAD program"+
→ **FWD/EDIT** **▶** (yes key) → **2** → **0** or **2-7** → **FWD/EDIT** **▶** (save key)
0: Toll saver
2-7: The unit answers after the selected number of rings.

Recording a Greeting Message

You can record a personal greeting message of up to 2 minutes. All messages (greeting, Incoming, etc.) are stored in digital memory. The total recording time is about 15 minutes.

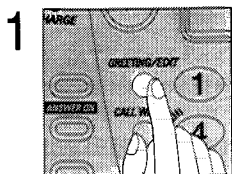

Press and hold **GREETING/EDIT** until a beep is heard.

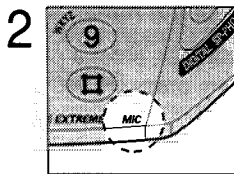

Talk into the **MIC**.

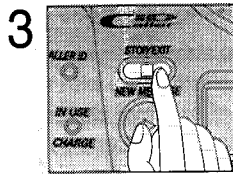

When finished, press **STOP/EXIT**.

- To check the greeting message, press **GREETING/EDIT** briefly.
- If you do not record a greeting message, a pre-recorded greeting will be played when a call is received.

Setting the Unit to Answer Calls

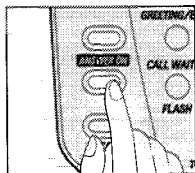

Press **ANSWER ON** to turn on the answering system.

- The indicator lights and "Answer set" is heard.
- The unit will announce the remaining recording time if it is less than 5 minutes.

If "Memory full" is heard, "Message full" flashes on the base unit and the ANSWER ON indicator flashes rapidly, erase some, or all, of the messages.

Listening to Messages

The base unit display shows the total number of recorded messages. If the ANSWER ON indicator light flashes, new messages have been recorded.

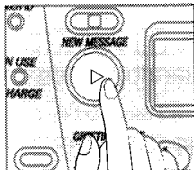

To play back new messages, press **NEW MESSAGE** briefly.

To play back all messages, press and hold **NEW MESSAGE** until playback starts.

• To adjust the speaker volume, press **▼** or **▲**.

- To erase a message, press **ERASE/CLEAR** while the message is being played.
- To erase all messages, press **ERASE/CLEAR** twice.

Panasonic

Caution-To comply with FCC RF exposure requirements, the base unit should be installed with its antenna located at 20 cm or more from persons and handset should be carried with the specific belt-clip provided for the handset to ensure compliance. Other non-tested belt-clips or similar body-worn accessories may not comply, therefore, should be avoided.

TOMORROW'S SERVICE AT TODAY'S PRICES!

**RESPOND PROMPTLY AND RECEIVE
AN "EARLY BIRD" DISCOUNT!**

1-800-637-2007

*USE THE CONVENIENCE OF OUR
TOLL-FREE CUSTOMER CARE PLAN HOTLINE:*

An extended service plan that assures
continued top performance 04 your
electronic product after the
factory warranty has expired!

USA ONLY

**THE
Panasonic
CUSTOMER
CARE PLAN**

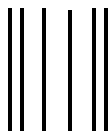

**NO POSTAGE
NECESSARY
IF MAILED
IN THE
UNITED STATES**

BUSINESS REPLY MAIL
FIRST-CLASS MAIL PERMIT NO 110 ELGIN IL

POSTAGE WILL BE PAID BY THE ADDRESSEE

Panasonic Quasar Technics'

**CUSTOMER CARE PLAN ADMINISTRATION
PANASONIC SERVICES COMPANY
545 TOLLGATE RD STE C
ELGIN IL 60123-9964**

